

BAJA SAE

Collegiate Design Series
Baja SAE[®] Rules

2024

Revision B

21 Sep 2023

Foreword

Welcome to Baja SAE® 2024!

For the 2024 season, there are several significant rule changes which warrant some explanation of rationale. For the complete list of rule changes, see the next section, as well as the proposed rule changes for the 2025 season. The following are the major changes for 2024 competitions:

New Engine Supplier

Kohler is the new engine supplier for the Baja SAE Series. Kohler has partnered with SAE International for the 2023-2026 Baja SAE Series competitions. Kohler, an engine manufacturer with a history of more than 100 years, is more than proud to support the future engineers who have so much passion to run in these competitions. The Baja SAE Series will require teams to operate vehicles using the Kohler CH440 engine with a competition kit. Engine CAD drawings and 3D shell models will be available online at bajasae.net under Series Resources.

Frame Definitions

Many changes to the frame section have been made to improve clarity and understanding. Improvements of distinctions between tubes, members, and gussets have been made. Welding Process check has been clarified, the Under Seat Member has been deleted and replaced with Under Seat Tube. The use of Docol tubing has been clarified, as well as changes to the primary members, secondary members and additional support tubes. Please be sure to carefully read all of the frame rules and utilize the Baja SAE rules inquiry feature on Bajasae.net if you have any questions.

Frame Fabrication

The purpose of the updates to Article 5 is to ensure students complete all aspects of the SAE Collegiate Design Series objectives. A goal of the Baja SAE series is to develop well rounded engineers; the hands-on learning of in-house manufacturing of components is an important step to achieving that goal. The frame is the one subsystem that every team is expected to fabricate unless they lack the necessary equipment to do so. This is the only subsystem that teams cannot externally source and is unique to each team, so every team can be evaluated equitably. Recently, a trend has developed where teams were choosing to have their frame professionally fabricated instead of manufacturing it themselves.

Purchasing a professionally fabricated frame removes a critical aspect of the educational value of the series. To ensure the Baja SAE series retains its status as a premier collegiate engineering design competition, the rules committee voted to clarify and modify rules around professional fabrication. The Baja SAE Rules Committee firmly believes that designing, integrating, fabricating, and assembling the vehicle frame causes team members to develop skills that are critical to the Baja SAE student experience. Furthermore, it is the belief of the Baja SAE Rules Committee that the act of physically fabricating, fitting, and welding the vehicle frame provides very important insight that drastically improves the future designs and drawings created by those team members, improving their future performance

even in situations where they are no longer doing the fabrication. Like many situations in Baja SAE, it is the difficulty and struggle that refine and guide the team members into the best practices.

From the collective professional experience of the Baja SAE Rules Committee, the knowledge and skills do not develop to the level the committee feels is critical when a team chooses to outsource some or all of the fabrication activity of the vehicle frame, even if the students created the design and welded the finished product together. While it might not be enjoyable in the moment, these experiences always yield more well-rounded team members and superior future engineers. Furthermore, to encourage teams to fabricate their own frame, the cost reporting system has been updated to increase the cost of outsourced components of a frame to five(5) times the cost of work completed by a team. The corresponding rules have been clarified to reflect this understanding, and to strongly encourage all teams that could possibly have or obtain the means to participate fully in the Baja SAE experience do so and to develop these critical skills).

Baja SAE® 2024 - List of Rule Changes

Caution: The following is not an exhaustive list of the rule changes. Neither this list of updates and changes nor any summary is a substitute for thoroughly reading and understanding the rules. Teams should regularly check www.bajasae.net/go/news for news and updates.

Teams are required to read and comprehend the rules. Read the rules early and often.

B.2.7.9 - Engine linkage minimum clearance

B.2.7.11 - Air cleaner relocation prohibited

B.2.7.14 – Required minimum clearance to muffler

B.2.7.14 – Relocation of muffler prohibited

B.3.2 – Major edits to entire section, including primary and secondary members and tubes definition. Additional support tubes, secondary member table, LC, RRH, RHO, Gussets, LFS, SIM, USM Deleted, FBM, FAB, Butt Joints, Welding Process Check, Roll Cage Materials, Sleeved Members all have been updated.

B.4.5.3.3 - Seat structure and tab mounting updated

B.5.1 - Snell M2020 and ECE R22-06 added, Snell M2015 deleted

B.5.4.4 – Flame Resistant pants now required

B.6.5 – Fuel tank coatings, paint, sticker prohibition clarified.

B.6.5.1 – Fuel tank fastener stack up updated

B.6.6.1 - Fuel hose clamps updated to Size #4

B.6.6.3 – Fuel hose size updated to 3/16 in.

B.6.7 - Splash shield requirements clarification

B.7.1 – Updated braking system performance

B.9.2.2.1 - clearance - figure B50?

B.10 – Clarified cut out switch restrictions

B.10.1.1.3 – Added battery capacity requirements

B.10.3 – Updated kill switch content

B.10.3.3.1 – Cockpit kill switch requirements

B.10.3.4 – Kill switch clearance requirements

B.10.4.1.2 – Brake light visibility envelope updated.

B.13.3.1 – Number requirements updated

B.13.3.7 – Number color requirements updated.

C.4.4.2 - Cost eligibility updated

D.2 - Safety Check updated

Rev B Updates (Post 2023 BSAE Ohio)

A.6.2.2 - Multiple entries per school now permitted.

B.2.2 - Engine sourcing requirement updated.

Figure B-9 : Secondary member support centered.

B.6.6.3 - Updated and clarified 3/16 in fuel line requirement

B.6.7 - Added clarity on splash shield function requirements.

B.9.2.2.1 - Added clarity on requirements for HROE periphery overlap length.

B.9.4 - Added clarity on horizontal requirement for gearbox breather hose extents.

B.10.3.3.2 - Added limits on kill switch orientation angle.

Baja SAE® 2025 - Proposed Rule Changes

1. A spec seat or seats may be required.
2. B.12.2 Updates to required tab geometry to improve options for teams
3. Requirement for Quick Disconnect fasteners on all body panels to facilitate faster technical inspection.
4. Requirement for specific ratings on all fire resistant garments.
5. More detail in A.1.4 for vehicle requirements.
6. Improvements to fuel tank bracket requirements to increase design options for teams.

Table of Contents

Table of Contents	7
Part A : Administrative Regulations	11
Article 1 - Baja SAE® Overview.....	11
Article 2 - Competition Information.....	12
Article 3 - Rules and Organizer Authority	13
Article 4 - Participation Requirements	15
Article 5 - Vehicle Eligibility	17
Article 6 - Registration.....	18
Article 7 - Report Submission	20
Part B : Technical Requirements	22
Article 1 - General Design Requirements	22
Article 2 - Engine.....	24
Article 3 - Roll Cage	30
Article 4 - Driver Restraint.....	54
Article 5 - Driver Equipment.....	66
Article 6 - Fuel System.....	68
Article 7 - Vehicle Controls.....	74
Article 8 - Cockpit.....	77
Article 9 - Powertrain Guards.....	82
Article 10 - Electrical System	87
Article 11 - Tow Points	91
Article 12 - Fasteners and Attachments.....	93
Article 13 - Vehicle Identification and Markings	95
Part C : Static Events.....	103
Article 1 - Scoring Summary	103
Article 2 - Technical Inspection	103
Article 3 - Design Evaluation.....	105
Article 4 - Cost Evaluation.....	108
Article 5 - Business Presentation (BP).....	110
Part D : Dynamic Events.....	112
Article 1 - Scoring Summary	112
Article 2 - Safety Check	112
Article 3 - Practice.....	112
Article 4 - Acceleration	113
Article 5 - Traction	114
Article 6 - Maneuverability.....	116
Article 7 - Specialty Events	117
Article 8 - Endurance	118
Article 9 - General Event Procedures and Regulations	124
Part E : Appendices	136
Article 1 - List of Abbreviations	136

Table of Figures

Figure B-1: Engine Governor.....	27
Figure B-2: Optional Low Profile High Speed Bracket PN 17 126 157	28
Figure B-3: High Speed Screw Access	28
Figure B-4: Muffler clearance envelope.....	29
Figure B-5: Approved Exhaust Deflector	30
Figure B-6: Roll Cage, Bend and Member Termination	31
Figure B-7: Roll Cage, Primary Members (filled in black), Front Braced Frame	32
Figure B-8: Roll Cage, Primary Members (filled in black), Rear Braced Frame.....	33
Figure B-9 : Secondary member support	34
Figure B-10: Roll Cage Example, Named Points, 'Nose; Car with Rear Bracing.	35
Figure B-11: Roll Cage Example, Named Points, Front Bracing	36
Figure B-12: Roll Cage, LC	37
Figure B-13: Roll Cage, RRH	38
Figure B-14: Roll Cage, LDB	39
Figure B-15: Roll Cage, RHO	40
Figure B-16: Roll Cage, Template Installation.....	41
Figure B-17: Roll Cage Template Drawing.....	41
Figure B-18: Roll Cage, Gussets.....	42
Figure B-19: Roll Cage 'Nose' Example, LFS	43
Figure B-20: Roll Cage 'Nose' Example, SIM	44
Figure B-21: Roll Cage 'Nose' Example, UST.....	45
Figure B-22: Roll Cage, FBM	46
Figure B-23: RHO / FBM Gussets	47
Figure B-24: Roll Cage, FAB	48
Figure B-25: Roll Cage, Butt Joint Sleeve	49
Figure B-26: Roll Cage, Welding Sample 1.....	50
Figure B-27: Roll Cage, Welding Sample 2.....	50
Figure B-28: Roll Cage, Required Joint for Removable Members	53
Figure B-29: Roll Cage, Required sleeve for drilled holes	53
Figure B-30: Driver Harness Schematic.....	55
Figure B-31: Driver Harness, SFI Tag, Old Style (Left), New Style (Right).....	56
Figure B-32: Driver Harness, Shoulder Harness Vertical Position	57
Figure B-33: Driver Harness, Shoulder Harness Lateral Position	57
Figure B-34: Driver Harness, Shoulder Harness Lateral Restraint	58
Figure B-35: Driver Harness, Diagram of Proper Wrapping of Webbing	58
Figure B-36: Driver Harness, Lap Belt Angle	60
Figure B-37: Driver Harness, Lap Belt Tab Orientation.....	60
Figure B-38: Driver Harness, Anti-Submarine Belt Angle	62
Figure B-39: Driver Harness, Anti-Submarine Belt Redirection	63
Figure B-40: Driver Harness, Arm Restraints	64
Figure B-41: Seat Angle	65
Figure B-42: Driver Equipment, Example Snell Sticker.....	66
Figure B-43 : Driver Equipment, Example ECE Tags	67

Figure B-44: Driver Equipment, Neck Support	67
Figure B-45: Fuel Tank Fastener Stack-up	70
Figure B-46: Fuel tank mounted to square/rectangular tubes (preferred mounting design)	70
Figure B-47: Fuel tank mounted to "C" brackets. (Acceptable mounting design)	71
Figure B-48: Allowable Taper	71
Figure B-49: Minimum weld length	72
Figure B-50: Fuel System, Splash Guard Installation Example	74
Figure B-51: Incorrect orientation of extinguisher clamps.....	81
Figure B-52: Incorrect routing of hose clamps.	81
Figure B-53: Fire Extinguisher, Diagram of Clearance around Pull Knob (green)	82
Figure B-54: Powertrain Guard Extent example on a CVT	83
Figure B-55: Driveshaft Guarding	84
Figure B-56: Powertrain Guard Example.....	85
Figure B-57: Air Trap Vent Line Routing	86
Figure B-58: Engine Kill Switch Mounting Position	89
Figure B-59: Tow Point, Inspection Tool Fitment	92
Figure B-60: Tow Point, Table of Tow Point Dimensions	92
Figure B-61: Tow Point, Rear Tab Dimensions	92
Figure B-62: Fasteners, acceptable markings.....	94
Figure B-63: Required Tab Drawing.....	95
Figure B-64 : Tab Requirements	95
Figure B-65: Table of transponder information.....	96
Figure B-66: Transponder Orientation.....	97
Figure B-67: Transponder, Mounting Location.....	98
Figure B-68 : Approved vehicle number font examples.	99
Figure B-69: Vehicle Numbers, Example	100
Figure B-70: RFID Tag Dimensions	101
Figure B-71: RFID tag location	101
Figure C-1: Static Events, Table of Points	103
Figure D-1: Dynamic Events, Table of Points	112
Figure D-2: Endurance Event, Table of Penalties	122
Figure D-3: Endurance Event, Table of Bonus Points.....	123
Figure D-4: Signals and Signage, Green Flag	129
Figure D-5: Signals and Signage, Yellow Flag	130
Figure D-6: Signals and Signage, Red Flag	130
Figure D-7: Signals and Signage, Black Flag.....	131
Figure D-8: Signals and Signage, Checkered Flag	131
Figure D-9: Signals and Signage, Directional Arrow	131
Figure D-10: Signals and Signage, Control Zone Boundary	132
Figure D-11: Signals and Signage, Time Control Marshal.....	132
Figure D-12: Signals and Signage, Start Line	133
Figure D-13: Signals and Signage, Finish Line	133
Figure D-14: Signals and Signage, Stop Sign	133
Figure D-15: Signals and Signage, End Control Zone	134
Figure D-16: Signals and Signage, Begin Fuel Zone	134
Figure D-17: Signals and Signage, End Fuel Zone.....	134
Figure D-18: Signals and Signage, Begin Service Area.....	135

Part A : Administrative Regulations

Article 1 - Baja SAE® Overview

A.1.1 - Program History

The Baja SAE® competition series originated at the University of South Carolina in 1976, under the direction of Dr. John F. Stevens. Since that time, the Baja SAE® Series has grown to become a premier engineering design series for university teams.

A.1.2 - Collegiate Design Series Objective

SAE International's Collegiate Design Series (CDS) programs prepare undergraduate and graduate engineering students in a variety of disciplines for future employment in mobility-related industries by challenging them with a real world, engineering application.

Through the Engineering Design Process, experiences may include, but are not limited to:

- Project management, budgeting, communication, and resource management skills
- Team collaboration
- Applying industry rules and regulations
- Design, build, and test the performance of a real vehicle
- Compete with other students from around the globe
- Develop and prepare technical documentation

Students also gain valuable exposure to and engagement with industry professionals to enhance 21st century learning skills, to build their own network, and help prepare them for the workforce after graduation.

A.1.3 - Baja SAE Program Objective

Baja SAE® is an intercollegiate engineering design competition for undergraduate and graduate engineering students. The object of the competition is to simulate real-world engineering design projects and their related challenges. Each team is competing to have its design accepted for manufacture by a fictitious firm. The students must function as a team to design, engineer, build, test, promote and compete with a vehicle within the limits of the rules. They must also generate financial support for their project and manage their educational priorities.

A.1.4 - Design Subject

Each team's goal is to design and build a single-seat, all-terrain, sporting vehicle whose driver is contained within the structure of the vehicle. The vehicle is to be a prototype for a reliable, maintainable, ergonomic, and economic production vehicle which serves a recreational user market, sized at approximately 4,000 units per year. The vehicle should aspire to market-leading performance in terms of speed, handling, ride, and ruggedness over rough terrain and off-road conditions. Performance will be measured by success in the static and dynamic events which are described in the Baja SAE® Rules, and are subject to event-site weather and course conditions.

BSEAE vehicles will be required to have 4-wheel drive (4WD) or all-wheel-drive (AWD).

Article 2 - Competition Information

A.2.1 - Competitions

SAE International will host up to three competitions within the United States and Canada in a given competition year. Locations will change yearly and are dependent on local support of SAE Sections, Universities, and Sponsor Companies.

Competitions outside the US and Canada include:

- Baja SAE Brazil, hosted by SAE Brazil
- Baja SAE Korea, hosted by Yeungnam University
- Baja SAE South Africa, sponsored by Sasol and hosted by Gerotek Test Facility
- Baja SAE Mexico, hosted by SAE Mexico

A.2.2 - Official Announcements

Teams are required to read the articles posted on www.bajasae.net/go/news published by SAE International and the other organizing bodies. Teams must also be familiar with all official announcements concerning Rules Clarifications released on the Downloads page on BajaSAE.net. SAE also has the Mobile Baja SAE phone app available on Apple iTunes and Google Play. Competitors are encouraged to download this app to keep up to date with competition news and announcements.

A.2.3 - Official Languages

The official language of the Baja SAE® Series is English. Document submissions, presentations and discussions in English are acceptable at all competitions in the series. Team members, judges, and officials at non-U.S. competition events may use their respective national languages for document submissions, presentations and discussions if all the parties involved agree to the use of that language.

A.2.4 - SAE International Technical Standards Access

A cooperative program of SAE International's Education Board and Technical Standards Board is making some of SAE International's Technical Standards available to teams registered for any US and Canadian Collegiate Design Series (CDS) competition at no cost. The Technical Standards referenced in the CDS rules, along with other standards with reference value, will be accessible online to registered teams, team members and faculty advisors.

A.2.4.1 - Eligibility

To access the standards your team must be registered for a competition in North America and the individual team member or faculty advisor wanting access must be affiliated to the team on SAE International's website (www.sae.org).

A.2.4.2 - Access Procedure

Once registered, a link to SAE MOBILUS will appear to access the technical standards under "Design Standards" on your team's profile page on sae.org, where all the required onsite team information is added. On SAE MOBILUS, you will have the ability to search standards either by J-number assigned or topic of interest such as brake light.

Article 3 - Rules and Organizer Authority

A.3.1 - Rules Authority

The Baja SAE® Rules are the responsibility of the Baja SAE® Rules Committee and are issued under the authority of SAE International. Official announcements from the Baja SAE® Rules Committee, SAE International, National Technical Inspectors (NTI) or the other Baja SAE® Organizers shall be considered part of and have the same validity as these rules. Ambiguities or questions concerning the meaning or intent of these rules will be resolved by the Baja SAE® Rules Committee, National Technical Inspectors, or SAE International Staff during competition onsite.

A.3.2 - Rules Variation

Some sections of rules governing Baja SAE® events held outside the U.S. and Canada are specific to these competitions. Such variations are published on the individual websites.

A.3.3 - Rules Validity

The newest revision of the Baja SAE® Rules posted on the BajaSAE.net website and dated for the calendar year of the competition are the rules in effect for the competition. Rule sets dated for other years or older versions of the current year are invalid.

A.3.4 - Rules Compliance

By entering a Baja SAE® competition, the team members, faculty advisors and other personnel of the entering university agree to comply with, and be bound by, the rules and all rules interpretations or procedures issued or announced by SAE International, the Baja SAE® Rules Committee and other organizing bodies. All team members, faculty advisors and other university representatives are required to cooperate with, and follow all instructions from competition organizers, officials and judges.

A.3.5 - Rules Comprehension

Teams are responsible for reading, understanding and comprehending the rules in their entirety for the competition in which they are participating. The section and paragraph headings in these rules are provided to facilitate reading: they do not fully explain all the paragraph contents. Questions regarding rules may be submitted by registered users through the rules inquiry feature on BajaSAE.net.

A.3.6 - Rules Questions

A.3.6.1 - Privacy

By submitting a rules inquiry on BajaSAE.net, the submitter agrees that both question and the NTI's answer can be reproduced and distributed by SAE International, in edited versions, in any medium or format anywhere in the world.

A.3.6.2 - Duplication

The National Technical Inspectors (NTI) will answer questions that are not already answered in the rules or FAQs or that require new or novel rule interpretations. For example, if a rule specifies a minimum dimension for a part, the NTI's will not answer questions asking if a smaller dimension can be used.

A.3.6.3 - Submission

An electronic question submission system has been developed for the North American competitions. The current submission instructions are published on BajaSAE.net, accessible by clicking “Submit a Rules Question.”

A.3.6.4 - Documentation

Teams submitting questions are required to bring copies of the questions and answers with them to technical inspection.

A.3.6.5 - Response Time

Please allow a minimum of two (2) weeks for a response. The National Technical Inspectors (NTI) will respond as quickly as possible. However, responses to questions presenting new issues, or of unusual complexity, may take more than two weeks.

Note: Please keep in mind that final operating approval of any Baja SAE® vehicle can only be given onsite at the competition.

A.3.7 - Loopholes

It is virtually impossible for a set of rules to be so comprehensive that it covers all possible questions about the vehicle’s design parameters or the conduct of the competition. Please keep in mind that safety remains paramount during Baja SAE®, so any perceived loopholes should be resolved in the direction of increased safety of the competition.

A.3.8 - Participating in the Competition

Teams, team members as individuals, faculty advisors and other representatives of a registered university who are present onsite at a competition are “participating in the competition” from the time they arrive at the event site until they depart the site at the conclusion of the competition or earlier by withdrawing. All team members and faculty advisors are required to register with their team as part of their Fast Track Roster (Liability Waiver) and obtain a liability wristband at the registration table onsite. The Fast Track Roster can be found on your team profile page at www.sae.org. Your Fast Track Roster must be printed, signed by all team members, and brought to competition after finalized. Please note: Team members that are attending and not attending competition should be included on the Fast Track Roster.

A.3.9 - Violations of Intent

The violations of the intent of a rule will be considered a violation of the rule itself. Questions about the intent or meaning of a rule may be addressed to NTI or SAE International staff.

A.3.10 - Right to Impound

SAE International and the other competition organizing bodies reserve the right to impound any onsite registered vehicle at any time during a competition for inspection and examination by the organizers, officials and technical inspectors.

A.3.11 - General Authority

SAE International and the competition organizing bodies reserve the right to revise the schedule of any competition and/or interpret or modify the competition rules at any time and in any manner, that is, in their sole judgment, required for the safe and efficient operation of the event or the Baja SAE® series as a whole.

A.3.12 - Protests and Appeals

It is recognized that hundreds of hours of work are put into the design and construction of a vehicle. In the heat of competition, emotions may peak and disputes can arise. The organizers and SAE International staff will make every effort to fully review all questions and resolve problems quickly and efficiently.

A.3.12.1 - Preliminary Review

If a team has a question about scoring, judging, policies or any official action it must be brought to the Baja SAE® Program Manager's attention for an informal preliminary review.

If a team has a question about one of their results/scores they can file a Problem Report using the mobile.bajasae.net website while at the competition site. Additional details about how to file a Problem Report will be available at the competition site or on mobile.bajasae.net. A Problem Report is not a formal protest but should be initiated prior to a formal protest if possible.

A.3.12.2 - Cause

A team may protest any rule interpretation, score or official action (unless specifically excluded from protest) which they feel has caused some actual, non-trivial harm to their team, or has had a substantive effect on their score. Teams may not protest rule interpretations or actions that have not caused them any substantive damage.

A.3.12.3 - Format and Forfeit

All protests must be filed in writing and presented to the Baja SAE® Program Managers by the team captain or a designated student team member. In order to have a protest considered, a team must post a twenty-five (25) point protest bond, which will be forfeited if the protest is rejected.

Note: SAE International staff, judges or volunteers will not review any video footage as part of the protest.

A.3.12.4 - Protest Period

Protests concerning any aspect of the competition must be filed within 30 minutes of the end of the event to which the protest relates.

A.3.12.5 - Decision

The decision regarding any protest is final.

Article 4 - Participation Requirements

A.4.1 - Students

A.4.1.1 - Eligibility

Eligibility to compete is limited to undergraduate and graduate students to ensure this is an engineering competition rather than a race. Individual members of teams participating in this competition must satisfy the following requirements:

A.4.1.2 - Student Status

Team members must be enrolled as a degree seeking undergraduate or graduate student in a college or university. Team members who have graduated during the last seven (7) month period prior to the competition remain eligible to participate.

A.4.1.3 - Society Membership

Team members must be SAE members. Proof of membership, such as a membership card, may be required at the event registration and check-in. Students may join SAE International at: <http://www.sae.org/participate/members/join>. For more information, please contact collegiatecompetitions@sae.org.

A.4.1.4 - Age

Team members must be at least eighteen (18) years of age at the time of the competition.

A.4.1.5 - Driver's License

Team members who will drive a competition vehicle at any time during a competition must hold a valid, government issued driver's license. All drivers must present their driver's license at the time of Technical Inspection.

A.4.1.6 - Fast Track Liability Waiver

All onsite participants and faculty are required to sign their team's Fast Track Roster (liability waiver) prior to or upon registering onsite.

A.4.1.7 - Insurance

Individual medical and accident insurance coverage is required and is the sole responsibility of the participant.

A.4.2 - Faculty Advisors

A.4.2.1 - Faculty Advisor Status

Each team is expected and encouraged to have a Faculty Advisor appointed by the university. The faculty advisor is expected to accompany the team to the competition and will be considered by competition officials to be the official university representative.

A.4.2.2 - Age

Faculty Advisors must be at least eighteen (18) years of age at the time of the competition.

A.4.2.3 - Fast Track Liability Waiver

All onsite participants and faculty are required to sign their team's Fast Track Roster (liability waiver) prior to or upon registering onsite.

A.4.2.4 - Faculty Advisor Responsibilities

Faculty Advisors are expected to advise their teams on general engineering and engineering project management theory.

A.4.2.5 - Faculty Advisor Limitations

Faculty advisors may not design any part of the vehicle nor directly participate in the development of any documentation or presentation.

Faculty Advisors may neither fabricate nor assemble any components nor assist in the preparation, maintenance, testing or operation of the vehicle.

Faculty Advisors are not allowed to participate during technical inspection, cost audit or design presentations. The team captain or other designated members of the team must do all the presenting although Faculty Advisors may silently observe.

Faculty Advisors may not design, build or repair any part of the vehicle.

A.4.3 - Visa Requests

Affiliated team members will have the ability to print out a Registration Confirmation Letter for the individual event(s) that they are attending. Once a student team member affiliates themselves to their team's profile page on sae.org under their individual edit section, they will have the opportunity to print out their personalized letter with the following information: Student's Name, School's Name, the CDS Event Name, Official Dates and Location(s).

Caution: SAE International cannot and will not intervene with, call, send personal letters to, the State Departments, Embassies or Consulates of the United States or other governments on behalf of any meeting or event participant.

Teams requiring visas to enter to the United States are advised to apply at least sixty (60) days prior to the competition. Although most visa applications seem to go through without an unreasonable delay, occasionally teams have had difficulties and in several instances visas were not issued before the competition.

Caution: Apply early for visas.

Neither SAE International staff nor any competition organizers are permitted to give advice on visas, customs regulations or vehicle shipping. Nor will they intervene on either matter concerning the United States or any other country.

Article 5 - Vehicle Eligibility

A.5.1 - Student Created

The vehicle and associated documentation must be conceived, designed, manufactured, and fabricated by the team members without direct involvement from professional engineers, faculty, or professionals in the off-road and racing communities.

A.5.2 - Kit Vehicles Prohibited

Vehicles fabricated from a kit or published designs are ineligible to compete. Vehicles which have been professionally fabricated will be disqualified from the competition or receive a penalty.

A.5.3 - Frame

Teams must manufacture and fabricate their frame and all components of the frame. If a team does not have access to machine shop facilities with the necessary equipment to complete this work or a portion of the work, this situation must be documented on the professional fabrication and manufacturing form. This form is part of the Roll Cage documentation package.

A.5.3.1 - Tubes

Any tube(s) that are professionally fabricated must be indicated in the cost report.

A.5.3.2 - Welding

Any tubes that are professionally welded must be indicated in the cost report.

A.5.4 - Prefabricated Subassemblies

These rules do not exclude the use of prefabricated or modified sub-assemblies made up of commonly available components.

A.5.5 - Penalties

Teams violating any of the rules in this article will receive a penalty, which depending on the severity of the infraction, could include disqualification from the competition.

Article 6 - Registration

A.6.1 - Individual Registration

A.6.1.1 - Affiliation

All participating team members and faculty advisors must be sure they are individually affiliated to their respective school/university on the SAE International website <https://www.sae.org/participate/membership/join> through their team's profile page for each event in which they are participating.

A.6.1.2 - SAE Membership

If you are not an SAE International member, go to <http://www.sae.org/membership/join> and click Join SAE for Students. Please note all student participants must be SAE International members to participate in the events; this is not mandatory for faculty advisors. Faculty members who wish to become SAE International members should choose an option under the "Professional Membership" link.

A.6.1.3 - Faculty Advisor Affiliation

All faculty advisors who are not SAE International members are required to sign up for an SAE International Customer Account using their email address. Contact collegiatecompetitions@sae.org and provide the Customer Number obtained on my.sae.org and the university name to be correctly affiliated to the university.

A.6.1.4 - Student Affiliation

All student participants and faculty advisors must affiliate themselves to the appropriate school and team roster online.

A.6.1.5 - Required Information

Once students and faculty advisors have associated to their respective university team(s), all affiliated students and faculty must complete all requested information (i.e. Emergency Contact Information) on the team registration page. All team members, including Faculty Advisors, must affiliate prior to competition.

A.6.2 - Team Registration

A.6.2.1 - Online Registration

US and Canadian competition registration for Baja SAE® events held in the US and Canada must be completed online. Online registration must be done by either (a) an SAE International member or (b) the official faculty advisor connected with the university and recorded as such in the SAE International database.

A.6.2.2 - Restriction

Registration for Baja SAE® competitions held in the US and Canada is restricted to two (2) vehicles per university depending on available space. The second team will not be allowed to register until after all teams have had an opportunity to register their first car.

A.6.2.3 - Waiting List

Each competition shall have a waiting list limited to 60 vehicles. The waitlist will remain open until all spots are filled or closing date and time posted on the specific event website is reached.

A.6.2.4 - Registration Dates

Teams must register for each Baja SAE® competition they intend to enter by the specified date on the action deadline webpage for each competition.

A.6.2.5 - Fees

Registration fees must be paid to SAE International by the deadline specified on the specific competition website. Registration fees are not refundable and not transferrable to any other competition.

A.6.2.6 - Withdrawals

Registered teams for the Baja SAE® US and Canadian events that determine they will not be able to attend the competition are required to officially withdraw by emailing collegiatecompetitions@sae.org no later than (4) weeks before the event. Registration fees are NOT refundable or transferable. For events outside the U.S. and Canada, please visit the respective competition website for contact information.

A.6.2.7 - Failure to Meet Deadlines

All teams, both Registered and Waitlisted, for any Baja SAE® competition are required to submit all required documents prior to the competition. The required documents provide evidence their car complies with the frame rules, supports the technical inspection process, and provides material that the Cost and Design event judges need to evaluate the team during the competition. When these documents are not submitted, the judges cannot properly assess the vehicle or the team.

Teams that do not submit Cost, Design, Business Presentation Plan, or Technical documents typically do not come to the competition. Teams that do not notify the SAE CDS personnel they are withdrawing from competition create the following problems:

- Teams are still included in the static event schedules and judging time is wasted.
- The unused registration slot cannot be offered to a team on the waitlist.

Additionally, failure to submit the required Cost, Design, Business Presentation Plan, and Technical Documents is a clear violation of the rules. Any blank document submitted to subvert the submission date will be treated as failure to submit.

Therefore, it is the policy of SAE International that failure to submit the required Cost, Design, Business Presentation Plan, or Technical documents within five (5) days of the deadline will constitute an automatic withdrawal of your team. Your team will be notified by the 5th day that SAE has not received the documents and after six (6) days the team's registration will be cancelled and no refund will be given.

A.6.2.8 - Shipping and Customs

SAE International and the Baja SAE® organizers strongly recommend international teams ship their vehicles early in order to allow enough time to compensate for any delays that may occur in clearing Customs in the country of the competition. Please check with the Customs Service concerning the regulations governing the temporary importation of vehicles. Teams may want to consider using the services of a freight forwarder who is familiar with the international shipping of racing vehicles.

Vehicle shipments by commercial carrier must comply with the laws and regulations of nations from which, and to which, the vehicle is being sent. Teams are advised to consult with their shipping company or freight forwarder to be sure their shipment fully complies with all relevant customs, import/export and aviation shipping requirements.

Shipments must be sent in accordance with the guidance for each specific competition. Some organizers are unable to accept shipments prior to the event or at all. Consult the official event website at sae.org for details specific to the individual competition site.

Vehicle shipping procedures for the U.S. and Canadian competitions are published on the Baja SAE® website for each competition and are incorporated into these rules by reference. Neither SAE International staff nor the Baja SAE® competition organizers are permitted to provide advice on U.S. Customs matters.

Article 7 - Report Submission

A.7.1 - Required Submissions

All required reports shall be submitted through BajaSAE.net. The standard forms that are required for documentation and submissions at Baja SAE® competitions have been relocated to www.bajasae.net/go/downloads.

A.7.1.1 - Sign Up Procedure

To create an account for BajaSAE.net, click "Create an Account," and follow the instructions. All teams require a Team Captain on BajaSAE.net in order to approve additional members. Once the team captain has created an account it will remain valid until the team becomes dormant or no longer registers to compete.

Note - There may be a delay of up to three (3) business days between the time your team registers for a competition and BajaSAE.net recognizes the validity of your authentication number.

A.7.1.2 - Responsibilities and Restrictions

Each team must have at least one person with an account at BajaSAE.net and identified as the Team Captain. The Team Captain(s) have unique responsibilities on the site including accepting other team members for site access. Until the captain accepts a member's signup request that person cannot upload

team documents, view team documents, or ask rules questions. Team captains automatically have the same roles and privileges as their team members.

Team Member Restrictions - Team members must be approved by the Team Captain or the Faculty Advisor before being able to view or upload team documents.

Note - All team members are not required to be affiliated on bajasae.net, just the person uploading documents or asking rules questions.

Uploading Documents - All team members and the team captain have equal authority to upload and/or replace documents in the name of the team.

Document Access - Uploaded documents can only be viewed by (1) member of the submitting team, (2) authorized judges, technical inspectors and officials and (3) CDS staff.

Reminder - The website does not know what is intended for submission or what the submitter is thinking. Anything a team uploads to the site is considered to be an official action by the team.

[SAE.org](#) Website Actions

- 1) Update Team Website & Social Media
- 2) Pay Your Team Invoice
- 3) Affiliate all members through Team Profile
- 4) Reprint your Team Invoice
- 5) Print Registration Confirmation Letter
- 6) Print Participation Certificate
- 7) Print Fast Track Roster

[BajaSAE.net](#) Website Actions

- 1) Monitor News
- 2) Affiliate those Submitting Documents
- 3) Affiliate those Asking Rules Questions
- 4) Ask Rules Questions
- 5) Submit Required Documents

A.7.1.3 - Process

Teams competing in any US and Canadian Baja SAE® competitions must submit the following documents online through [BajaSAE.net](#).

- Cost Report
- Cost Documentation
- Design Review Briefing (DRB)
- Roll Cage Documentation Package
- Business Presentation

Documents may be uploaded to the website from the time the participant's Baja SAE® online account has been created and approved until the "No Submissions Accepted After Date" (which is 5 days after the due date). Submissions may be replaced with new (updated) uploads at any time before the due date without penalty. Teams have the option to replace uploaded documents with a new file at any time. However:

- Replacements after the "Submission Due Date" and the "No Submissions Accepted After Date" are classified as late submissions and the appropriate penalties will be applied.
- Documents may not be uploaded or replaced following the "No Submissions Accepted After Date."
- The latest and most recent document uploaded will be the document evaluated by judges.

A.7.1.4 - Deadline

Submissions must be received by the due date listed on the Action Deadlines on sae.org. Submission will be acknowledged on the submission website with a visual indicator. Teams should have a printed copy of this acknowledgement available at the competition as proof of submission in the event of discrepancy.

A.7.1.5 - Late Submission / Non-Submission Penalty

Late submission or failure to submit the Design Report and/or Business Presentation Plan and/or Cost Report will be penalized ten (10) points per day. If either report is received more than five (5) days late it will be classified as "Not Submitted" and your team's registration will be cancelled.

A.7.1.6 - Unsatisfactory Submission

At the discretion of the judges, teams who submit any report that, in the opinion of the judges, does not represent a serious effort to comply with the requirements as listed in these rules will also not compete in the design and/or event, but may at the design judges' discretion receive between five (5) and twenty (20) points for their efforts.

Part B : Technical Requirements

Article 1 - General Design Requirements

B.1.1 - General Requirements

The vehicle may only use one Kohler engine of a model specified below. The vehicle must be capable of carrying one (1) person 190 cm (75 in.) tall weighing 113 kg (250 lbs).

B.1.2 - Ergonomic Design

As a prototype of a commercial product, the design intent must accommodate drivers of all sizes from the 95th percentile male (in the country in which the competition is held) to the 5th percentile female. All drivers shall meet the roll cage minimum clearances, and fit into a comfortable driving position, while wearing the entire required driver's equipment. All drivers shall be able to comfortably reach all of the vehicle's controls.

Teams shall be prepared to demonstrate the compliance to this requirement in the design event.

B.1.3 - Good Engineering Practices

Vehicles entered into Baja SAE® competitions are expected to be designed and fabricated in accordance with good engineering and construction practices.

B.1.4 - All-Terrain Capability

B.1.4.1 - Terrain Type

The vehicle must be capable of safe operation over rough land terrain including obstructions such as rocks, sand, logs, steep inclines, mud, and shallow water in any or all combinations and in any type of weather including rain, snow and ice.

B.1.4.2 - Clearance and Traction

The vehicle must have adequate ground clearance and traction for the terrain type at the competition.

B.1.5 - Vehicle Configuration

B.1.5.1 - Wheel Arrangement

The vehicle must have four (4) or more wheels not in a straight line.

B.1.5.2 - Four-Wheel Drive / All-Wheel Drive

Teams shall design their vehicle for four wheel drive / all-wheel drive (4WD/AWD) operation. Demonstration of working 4WD/AWD will be required.

B.1.5.2.1 - Penalties

Teams may attempt the 4WD/AWD check at any time after Engine Tech and before Final Tech. Teams must pass 4WD/AWD check before the “passed tech” sticker will be issued.

Teams unable to successfully pass the 4WD/AWD check by 2pm local time on the Dynamic Events day will be allowed to compete the final stages of technical inspection and compete in the dynamic short events and the endurance event. However, such teams will not receive their final tech sticker until 2pm on dynamic short events day AND also a 4WD non-compliance penalty will be applied where appropriate.

The non-compliance penalty for each dynamic short event will be 35 points per event. The non-compliance penalty for the endurance event will be 200 points. The team’s score for each event will not drop below zero points even if a non-compliance penalty is assessed that would otherwise result in a negative score.

B.1.6 - Limitations

Width: 162 cm (64 in) at the widest point with the wheels pointing forward at static ride height.

Length: Unrestricted.

Weight: Unrestricted.

Note: Teams should keep in mind that Baja SAE® courses are designed for vehicles with the maximum dimensions of 162 cm (64 in.) width by 274 cm (108 in.) length.

B.1.7 - Technology Challenge

SAE International and the Baja SAE rules committee reserves the option to award up to and including 100 bonus points per team who successfully demonstrate specific technologies. If a technology challenge is added, a General Notice will be posted on the BajaSAE.net website prior to the competition registration date of the competition year. There will be no technology demonstrations added after that date for the competition year. The General Notice shall include a description of the technology, guidelines for

successful implementation, a timeline for implementation, and a scoring process. The notice will also contain information on any rules that will be waived or modified for a team that is precipitating in the technology challenge portion of the competition. The technology challenge will be optional for all teams.

SAE will work with sponsors who wish to fund incentives for specific technology challenges. Sponsors shall be required to support the technology demonstration for a minimum of two years. Sponsors shall work with Baja SAE rules committee to address any rules requiring modification to accommodate the technology. Sponsors shall be operationally responsible for the judgement and evaluation of the technology challenge.

Article 2 - Engine

B.2.1 - Required Engine

To provide a uniform basis for the performance events, all vehicles shall use the same engine: an unmodified, four-cycle, air cooled, Kohler CH440 with Baja SAE restriction plate.

B.2.2 - Engine Orders

Teams registered for Baja SAE competition managed by SAE International must purchase their discounted engines when registering for a competition online www.sae.org. Instructions to “Order an Engine” are available online at www.bajasae.net under Series Resources in Team Operations Resources folder.

B.2.3 - International Orders

Kohler will not ship engines outside of the continental United States or Canada. International orders must follow one of the shipping methods listed below. Exporting is not an option. If for any reason the engine fails to arrive, due to a team’s third-party shipper, it will not be replaced by Kohler or SAE.

Teams from countries outside of the continental U.S. and Canada will need to have their engines shipped to either one of the following:

- SAE International Headquarters or the event organizer for the event the team registered for.
- An address in the U.S. provided by the participating team.

Teams requesting that engines be shipped to the organizer will be responsible for installing the engine prior to technical inspection and will need to bring the tools necessary to install the engine onsite. Teams should also get permission from the organizer to use their facility if necessary.

B.2.4 - Additional Engines

Teams may purchase additional Kohler engines directly from Gardner Inc. (<http://www.gardnerinc.com>).

B.2.5 - Hybrid Electric Systems

Hybrid-electric drivetrain systems are explicitly prohibited. The use of a starter motor for the purpose of vehicle propulsion is explicitly prohibited.

B.2.6 - Energy Storage Devices

B.2.6.1 - Hydraulic

Hydraulic accumulators are the only type of stored energy device that may be incorporated into the vehicle for propulsion purposes. Hydraulic power systems must be properly shielded and documentation of the shielding made available for review. Teams shall provide a hydraulic power specification sheet at the time of technical inspection. The hydraulic power specification sheet is available at BajaSAE.net

B.2.6.2 - Kinetic

Kinetic energy storage devices, such as flywheels, are explicitly prohibited.

B.2.6.3 - Electric

Batteries or other electric energy storage device for vehicle propulsion are explicitly prohibited. Hybrid-electric vehicle propulsion systems are explicitly prohibited.

B.2.6.4 - Compressed Gas

Compressed gas systems for vehicle propulsion are explicitly prohibited.

B.2.7 - Engine Requirements and Restrictions

To provide a uniform basis for the performance events, all vehicles shall use the same engine: an unmodified four-cycle, air cooled, Kohler CH440 engine.

The required engine must remain completely stock (except for approved modifications) in all ways and include the Gardner Inc. Baja SAE conversion kit.

Approved Modifications (see “Engine Resources Section” on BajaSAE.net for more information)

- High Speed Setting Bracket (fuel tank mount OR low profile)
- Oil Level Sending Unit Disable
- Engine modifications per “Baja SAE Conversion Overview”
- Wiring modifications for kill switch
- Throttle modifications
- Charging system installation

Note: Blueprinting (reworking an engine to a manufacturer’s exact specifications) is considered to be a modification and is explicitly prohibited.

The only engine model accepted at all Baja SAE® U.S. and Canadian competitions is Kohler model number PA-CH440-3302

Note: No other engine models will be accepted.

The Kohler CH440 will come with a fuel tank which must be removed and replaced with the SAE specified fuel tank. A Kohler in-line fuel filter is required.

B.2.7.1 - Replacement Parts

Only Original Equipment Kohler replacement parts may be used. Consumable parts may be ordered on the Kohler website: <http://www.kohlerpower.com>, <http://www.gardnerinc.com> or procured from a Kohler dealer. When ordering parts use the specification number PA-CH440-3302.

B.2.7.2 - Piston Rings

Only standard size, original Kohler piston rings may be used.

B.2.7.3 - Intake Ports

No cleaning or removing of aluminum flashing from intake or exhaust ports may be done.

B.2.7.4 - Valves

Any valve clearance setting between tappet and valve stem may be set. Valves may be lapped to ensure proper sealing. Intake valve seat angle must remain at 45 deg. Exhaust valve seat angle must remain at 45 deg.

B.2.7.5 - Shafts and Rods

The camshaft, crankshaft, connecting rod, and flywheel must not be altered or modified.

B.2.7.6 - Spark Plugs

The only permitted spark plug is Kohler 25 132 19-S. No other spark plugs are permitted.

B.2.7.7 - Armature

Any armature air gap setting is allowed. The armature mounting holes shall not be slotted or elongated to increase or retard ignition timing.

B.2.7.8 - Flywheel Rotation

The flywheel shall not be rotated to advance or retard timing. The stock Kohler flywheel key must be used.

B.2.7.9 - Engine Governor

Each engine is equipped with a speed governor. Each governor will be set at the competition to 3,750 - 3,800 RPM. Kohler may perform random inspections of the governor on any vehicle and these may be conducted at any time. Any attempt to defeat the engine governor to increase the engine speed is grounds for immediate disqualification. A clearance of 13 mm (0.5 in) shall be maintained between any engine throttle and governor linkage and the nearest non-engine obstruction.

Caution: Governor setting not to exceed 3,800 RPM

The governor operation must remain free of obstructions at all times. Governor area must be shielded from debris. Teams may fabricate a control cover.

The governor spring shall be engaged with, and only with, hole 2B.

Governor spring part number: 17 089 64.

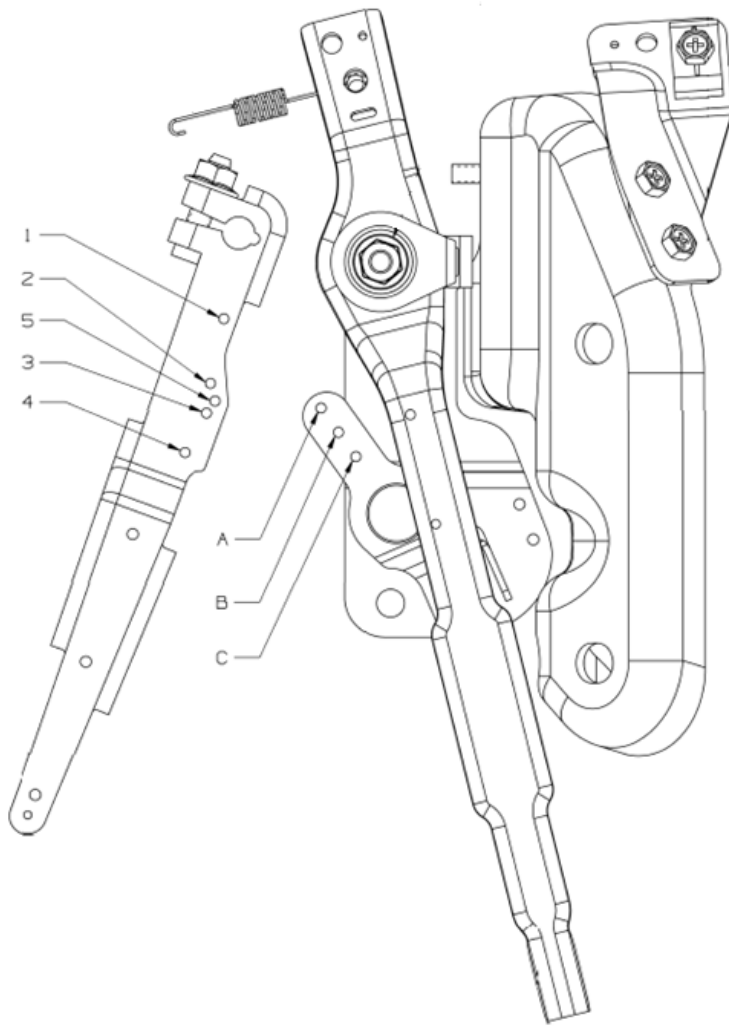

Figure B-1: Engine Governor

B.2.7.10 - Idle Speed

Any idle speed adjustment is allowed, Kohler recommends 1,800 RPM \pm 50 RPM.

B.2.7.11 - Air Cleaner

The OEM air cleaner for a PA-CH440-3302 must be used. Relocation of the air filter is not permitted.

B.2.7.12 - High Speed Setting Bracket

Changing the high speed setting bracket is permitted. Original High Speed Bracket and fuel tank support (Kohler PN 17 126 245) with CH440-3302.

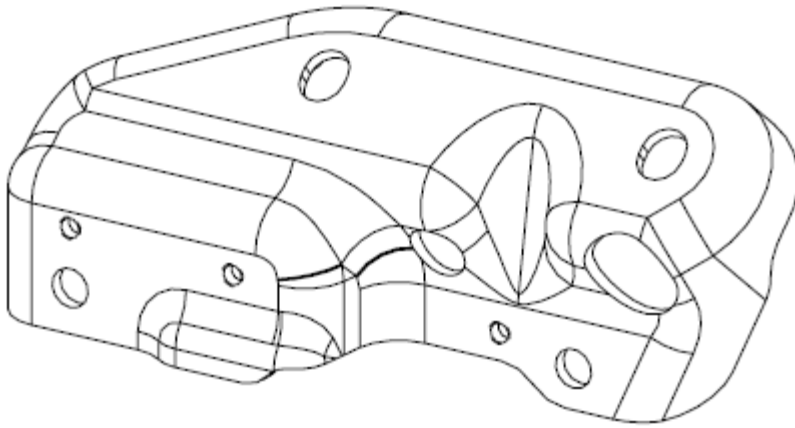

Figure B-2: Optional Low Profile High Speed Bracket PN 17 126 157

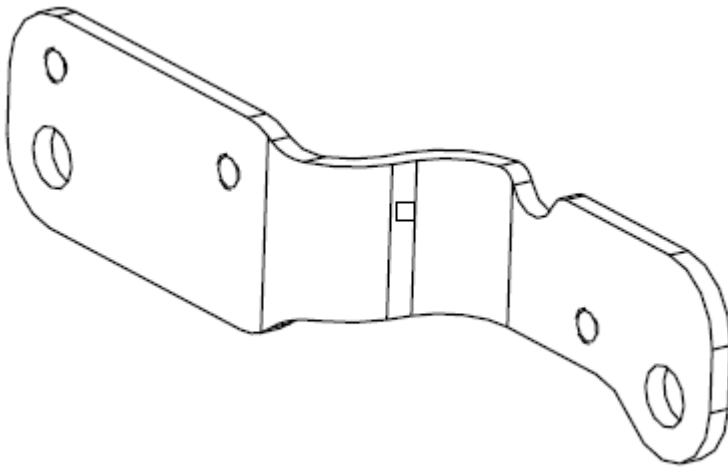

Figure B-3: High Speed Screw Access

There shall be access to the high speed setting screw to allow Kohler to make adjustments.

Option 1 – 3.0 inch access gap between the bolt head and firewall (or other obstruction)

Option 2 – 0.5 inch hole in the firewall in-line with the bolt head to allow access with a T25 torx bit. Hole must be sealed after engine setting with a grommet or sheet metal cover.

B.2.7.13 - Carburetor

B.2.7.13.1 - Jetting

Modifying the carburetor jet or re-jetting of the carburetor is prohibited.

B.2.7.13.2 - Float

The carburetor float is not adjustable and may not be modified.

B.2.7.13.3 - Venturi

Modification of the carburetor venturi is prohibited.

B.2.7.13.4 - Restriction Plate

An unmodified restriction plate purchased from Kohler / Gardner Inc. is required to be installed on the CH440 engine. Kohler and/or SAE NTI reserve the right to inspect the inside diameter of the restriction plate at any time during competition.

B.2.7.14 - Exhaust System

B.2.7.14.1 - Muffler Clearance

The muffler exit shall remain clear as defined by the cylindrical cross section depicted in Figure B-4. If an exhaust deflector is used, the centerline of the muffler exit cross section will be applied to the deflector exit port, less the space occupied by the muffler itself.

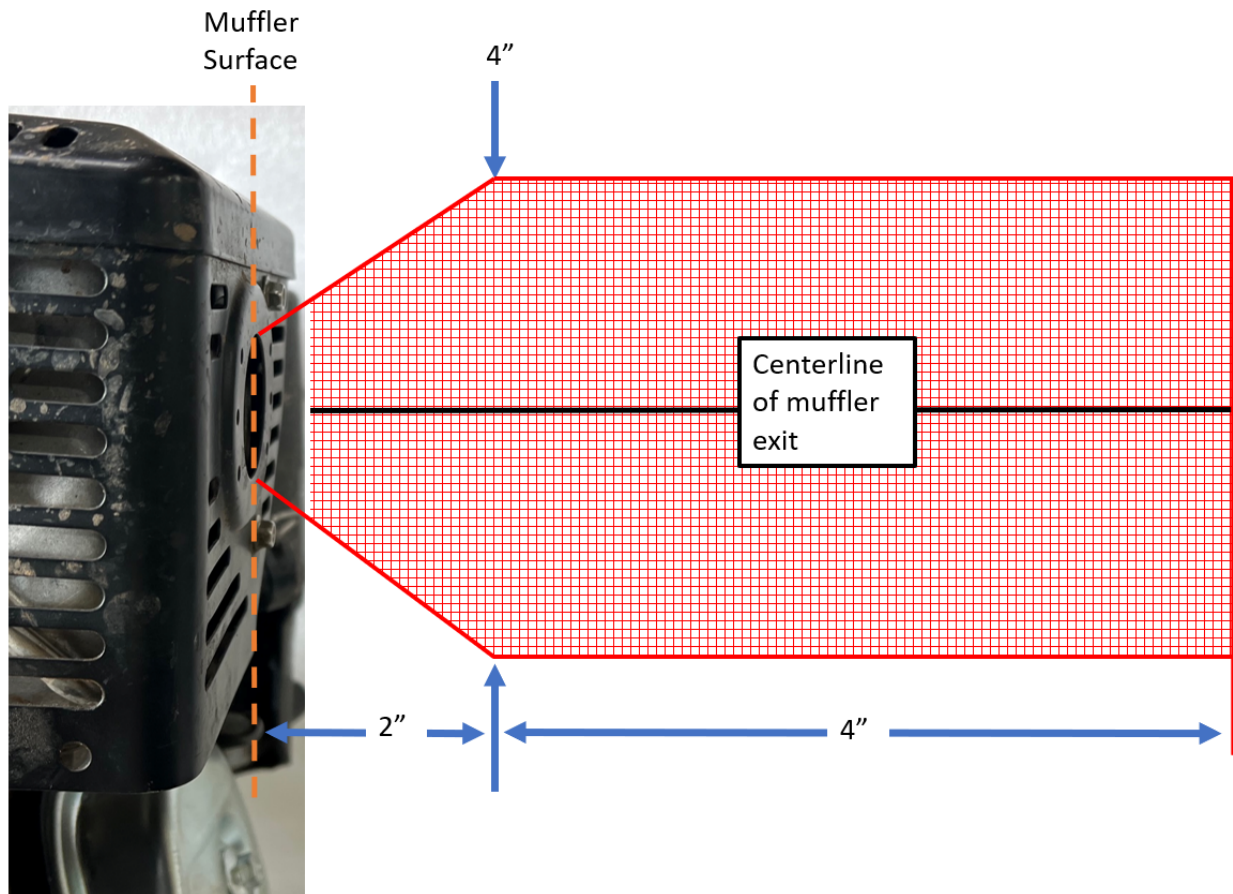

Figure B-4: Muffler clearance envelope

B.2.7.14.2 - Muffler Relocation

Muffler relocation is explicitly prohibited. An exhaust deflector may be used, PN 17 730 03 S.



Figure B-5: Approved Exhaust Deflector

B.2.7.14.3 - Muffler Cage

Teams are required to retain the OEM protective sheet metal cage surrounding the muffler to reduce risk of burns.

B.2.7.15 - Starting Devices

The starter pull rope may be extended to accommodate the driver starting the engine while seated. Starter motors are explicitly prohibited.

B.2.7.16 - Alternator

The engine may be fitted with an approved alternator to generate electrical power. The only permitted alternators are those alternators Kohler specifies for the engine model. Available alternators are sized in 3, 10 and 18 Ampere versions. Installation guidelines and part numbers provided in the resources section on BajaSAE.net.

Article 3 - Roll Cage

B.3.1 - Objective

The purpose of the roll cage is to maintain a minimum space surrounding the driver. The cage must be designed and fabricated to prevent any failure of the cage's integrity during normal operation or during a collision or roll over.

B.3.2 - Roll Cage Structure

The roll cage must be a space frame of tubular steel. The following section outlines the requirements of the physical members and joining methods of the roll cage. Roll cage and Frame Members must be fully welded, and welds must not be ground, sanded or modified so as to prevent inspection. Roll Cage Members that are bent must not exhibit any wrinkles, kinks or any detrimental deformation to the cross-section. Terminology used in the rule book relating to the roll cage structure is given below:

Frame: The entire tubular structure including required members and non-cantilevered tubes.

Roll Cage: Primary and Secondary Members used to protect the driver.

Tube: A Primary or Secondary element, which is not required to begin and end at Named Points, except where noted.

Member: A Primary or Secondary required element beginning and ending at Named Points.

Named Point: The intersection of the centerlines of two or more joining members.

B.3.2.1 - Member Requirements

Roll cage members must be made of steel tube and may be straight or bent. Straight members may not extend longer than 1016 mm (40 in.) between Named Points or comply with Rule B.3.2.4 - Additional Support Members. Bent members may not have a bend greater than 30 deg. that does not occur at a Named Point; and may not extend longer than 838 mm (33 in.) between Named Points or comply with Rule B.3.2.4 - Additional Support Members. Small bend radii (<152 mm or 6 in.) that terminate at Named Points are expected, and are not considered to make a member bent, regardless of angle. A bend that terminates at a Named Point implies the point lies at or between the points of tangency of the bend, as shown in Figure B-6. Required dimensions between roll cage members are defined by measurements between member centerlines, except where noted. Junctions of Primary and Secondary members described below must be within 51 mm (2.0 in) of the Named Point, except where noted.

Mitered tubing joints of greater than 5 deg. will be treated as bends. Miters of less than 5 deg. will be treated as butt joints and subject to Rule B.3.2.14 - Butt Joints. Required members constructed of multiple members, such as the SIM and LFS, will be judged as continuous members from Named Point to Named Point, except where noted.

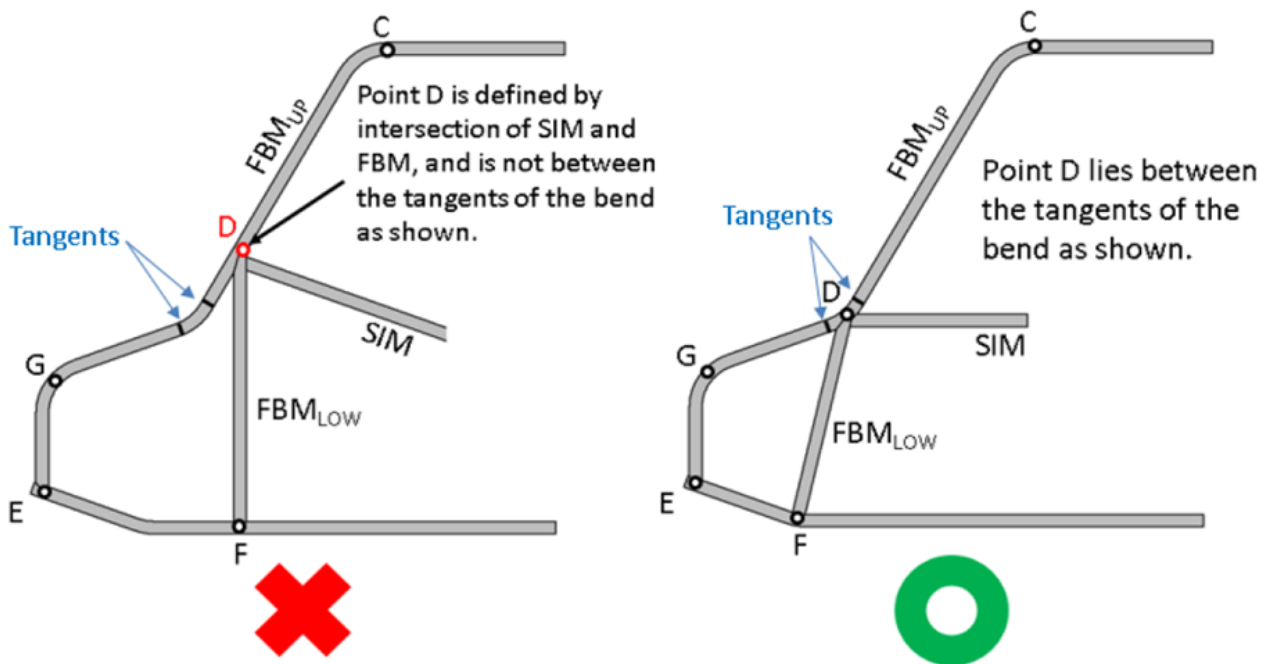

Figure B-6: Roll Cage, Bend and Member Termination

B.3.2.2 - Primary Members

The required members of the roll cage are illustrated in Figure B-7 and Figure B-8. Members shall always begin and end at Named Points. Tubes, where required, are not required to terminate at Named Points except where noted. Primary members and tubes shall conform to B.3.2.16 - Roll Cage Materials.

Primary members are:

- RRH: Rear Roll Hoop Members
- RHO: Roll Hoop Overhead Members
- FBM: Front Bracing Members (Upper, Lower, and Lower when present)
- ALC: Aft Lateral Cross Member
- BLC: Overhead Lateral Cross Member
- CLC: Upper Lateral Cross Member
- DLC: SIM Lateral Cross Member
- ELC: Nose SIM Lateral Cross Member (When Present)
- FLC: Front Lateral Cross Member
- GLC: Nose Front Lateral Cross Member (When Present)
- LFS: Lower Frame Side Members

Primary Tubes Are:

- B.3.2.8.1 - Gussets for Lateral Clearance
- B.3.2.12.1 - Gussets for RHO and FBM
- B.3.2.10 - Additional Structure for Driver Toe Protection

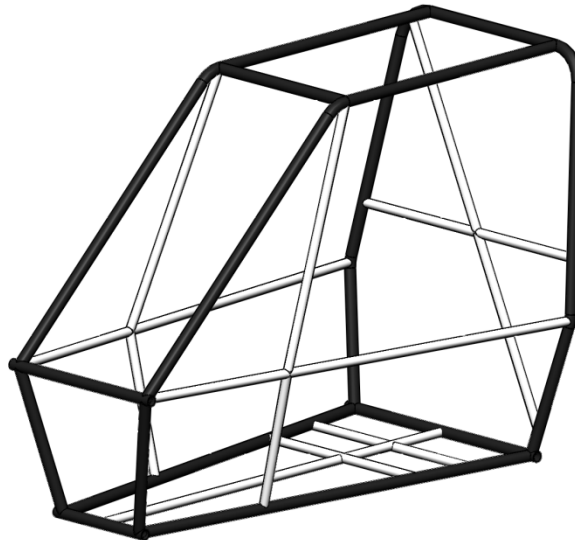

Figure B-7: Roll Cage, Primary Members (filled in black), Front Braced Frame

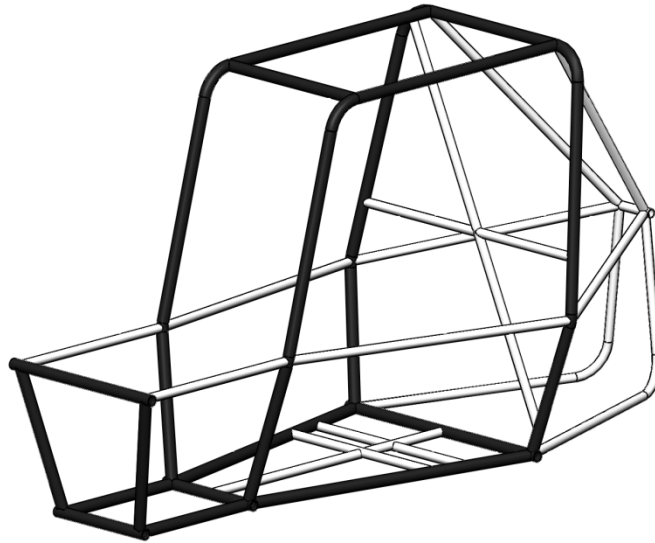

Figure B-8: Roll Cage, Primary Members (filled in black), Rear Braced Frame

B.3.2.3 - Secondary Members and Tubes

Secondary members and tubes shall be of tubular steel, having a minimum wall thickness of 0.89 mm (0.035 in) and a minimum outside diameter of 25.4 mm (1.0 in) or rectangular steel tubes having a minimum wall thickness of 0.89mm (0.035 in) and a minimum outside dimension of 25.4 mm (1.0 in).

Secondary members are:

- LDB: Lateral Diagonal Bracing Member(s)
- SIM: Side Impact Members
- FAB: Fore/Aft Bracing Members
- USM: Under Seat Member
- RLC: Rear Lateral Cross Member
- Any tube that is used to mount the safety belts or fuel tank or protect the fuel system

Secondary tubes are:

- B.3.2.11 - Under Seat Tube (UST)
- B.3.2.4 - Additional Support Tubes
- B.3.2.8.1 - Gussets for Lateral Clearance
- B.4.2 - Any tube used to mount safety belts
- B.6.5.1 - Any tube used to mount the fuel tank
- B.6.5 - Any tube used to protect the fuel system.

B.3.2.4 - Additional Support Members Tubes

For bent or straight Primary Roll Cage Members that exceed the maximum allowable length, Additional Support Tubes shall be added. For straight members, a single secondary tube shall connect from the mid-point (+/-127 mm or 5 in.) to a Named Point. For bent members, a single secondary tube shall connect from between the tangents of the bend to a Named Point. If Additional Support Tubes are used, the supported Roll Cage Member will be re-evaluated for length between Named Points and the location of the Additional Support Tube. Primary bent members shall not have a bend greater than 30 degrees.

For bent or straight Secondary Roll Cage Members that exceed the maximum allowable length or bend angle, Additional Support Tubes shall be added. For members that exceed only the allowable length OR the allowable bend angle, a single Additional Support Tube is required, with one end connected as described above and the other shall terminate within 2” of a Named Point . For members that exceed both the length AND bend angle limits, two Additional Support Tubes shall connect from between the tangents of the bend to two unique Named Points.

Note: As an exception to the definition of Tube in B.3.2.2 – Primary Members and Tubes, Additional Support Tubes shall have one end terminate at a Named Point.

SECONDARY MEMBERS ONLY			
Bend Angle \ Length	≤838mm (33in)	>838mm (33in) & <1016mm (40in)	>1016mm (40in)
0°	No Supports Required	No Supports Required	1 Support Member Required*
≤ 30°	No Supports Required	1 Support Member Required**	1 Support Member Required**
> 30°	1 Support Member Required**	2 Support Members Required**	2 Support Members Required**
* Required within 50mm (2in) of the midpoint of the overall tube length ** Required within the tangents of the bend			

Figure B-9 : Secondary member support

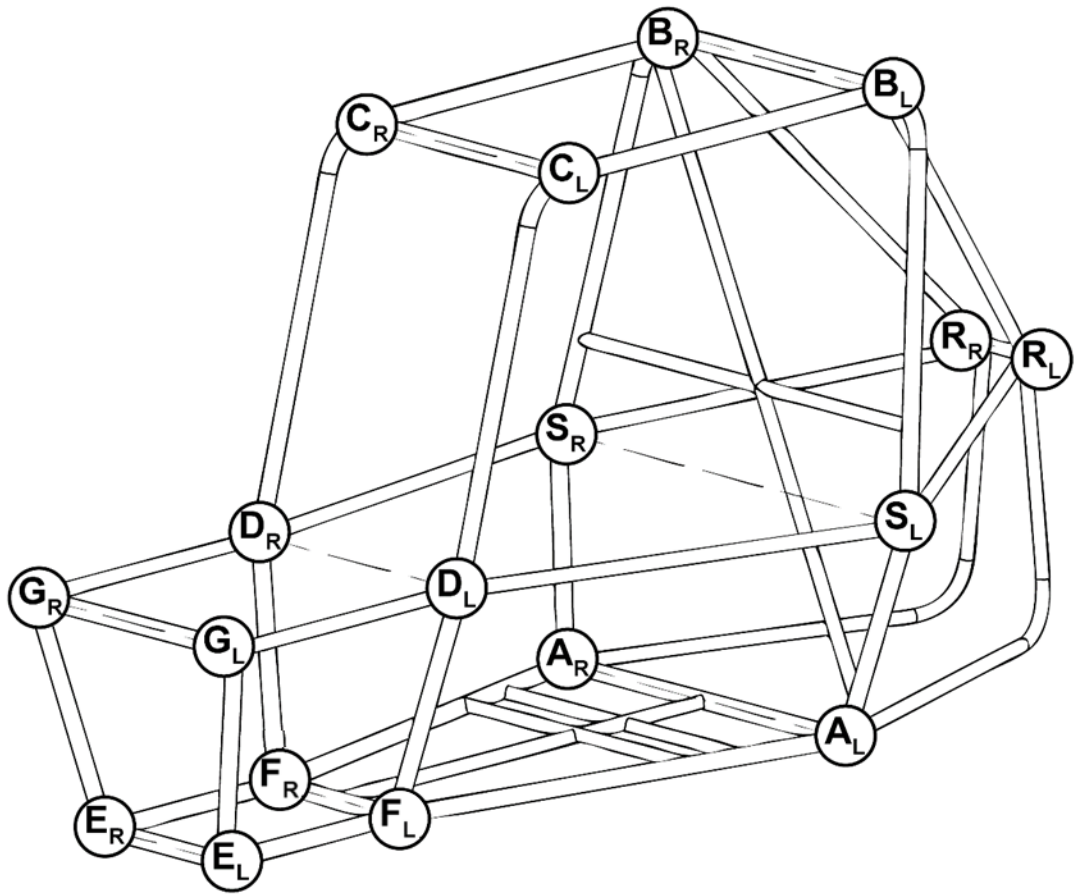

Figure B-10: Roll Cage Example, Named Points, 'Nose; Car with Rear Bracing.

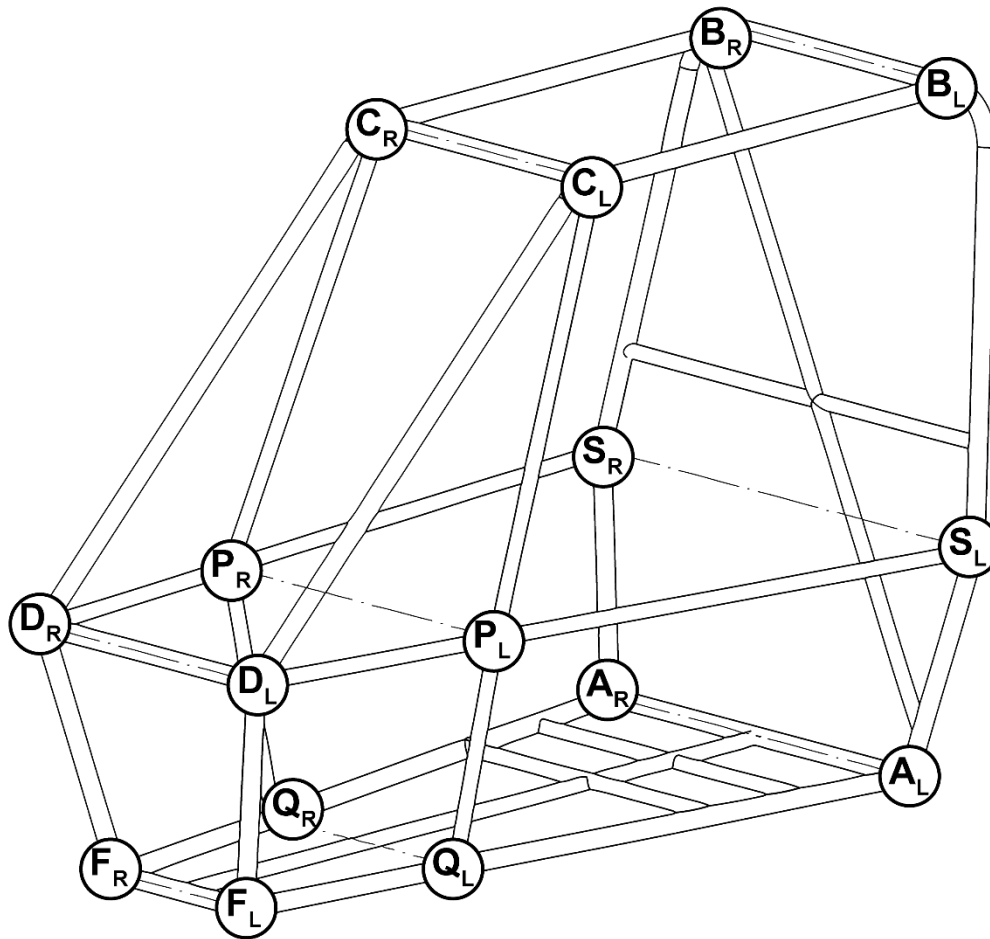

Figure B-11: Roll Cage Example, Named Points, Front Bracing

B.3.2.5 - LC – Lateral Cross Member

Lateral cross members (LC) shall not be less than 203.5 mm (8 in.) long. LCs shall not have a bend; however, they may be part of a bent system, provided the minimum length is met between bend tangents. LCs are denoted by the points they connect (e.g. ALC, FLC, etc.). The cross members which connect the left and right points A, B, C, D, F and E/G for 'Nose' cars (in which case DLC may be omitted) shall be made of primary materials. The LC at Point R for Rear FAB systems may be secondary material and must meet the minimum length described above.

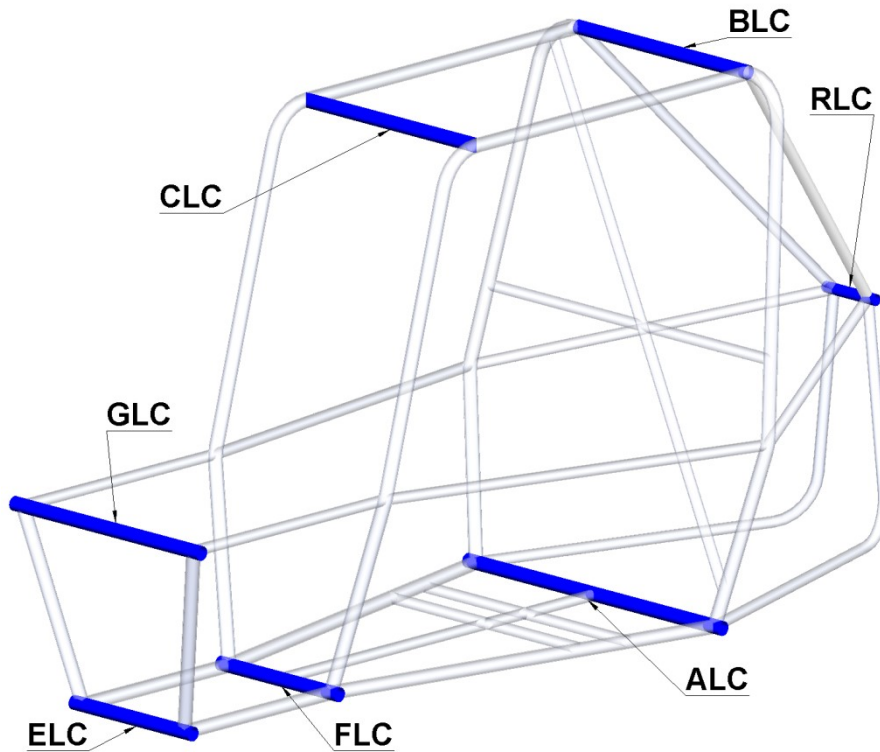

Figure B-12: Roll Cage, LC

Note: RLC is exists only with complete Rear Bracing per B.3.2.13.2

B.3.2.6 - RRH – Roll Hoop Members

The RRH is a planar structure behind the driver's back and defines the boundary between the front-half (fore) and rear-half (aft) of the roll cage. The driver and seat must be entirely forward of this plane. The RRH shall be inclined between 0 and 20 deg. from vertical as viewed from the side of the vehicle. The minimum width of the RRH is 736 mm (29 in.), measured at a point 686 mm (27 in.) above the inside seat bottom. The vertical members of the RRH may be straight or bent and are defined as beginning at Point A at the lower end and terminating at Point B at the upper end shown in Figure B-12. The vertical members shall be continuous from Point A to B (i.e. not multiple segments joined by welding). The vertical members shall be joined by Lateral Crossmembers ALC and BLC at the bottom and top for the RRH. ALC and BLC members must be continuous tubes or adhere to B.3.2.14 - Butt Joints.

Points AR/AL, at the lower end of the RRH vertical members, are defined as the intersection with the LFS and ALC.

Points BR/BL, are defined as the uppermost end of the RRH vertical members. For Roll Cages constructed with bends at the upper end of the vertical members, Point B occurs at the uppermost tangent of the bend. Point B is the intersection of the RRH vertical members with the RHO and BLC. Point B may not reside on the bend or a linear distance from the end of the bend.

Note: ALC, BLC, RRH members, LDB and the shoulder belt tube shall all be coplanar.

Note: Shoulder belt tube shall connect to the RRH vertical members at both ends.

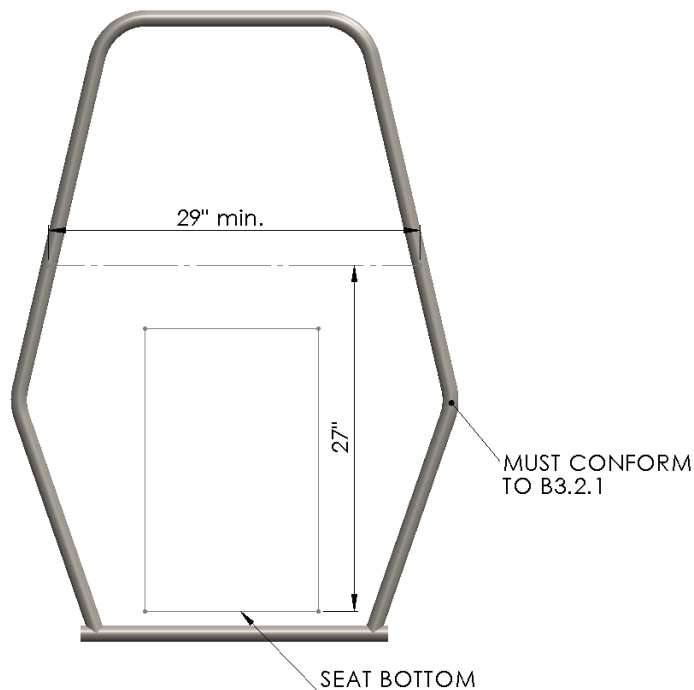

Figure B-13: Roll Cage, RRH

B.3.2.7 - LDB – Lateral Diagonal Bracing

The RRH must be diagonally braced. The diagonal brace(s) must extend from one RRH vertical member to the other. The top and bottom intersections of the LDB members and the RRH vertical members must be no more than 127 mm (5 in.) from points A and B. The angle between the LDB members and the RRH vertical members must be greater than or equal to 20 deg. Lateral bracing may consist of more than one member.

A single straight LDB is exempt from the maximum length in B.3.2.1 - Member Requirements.

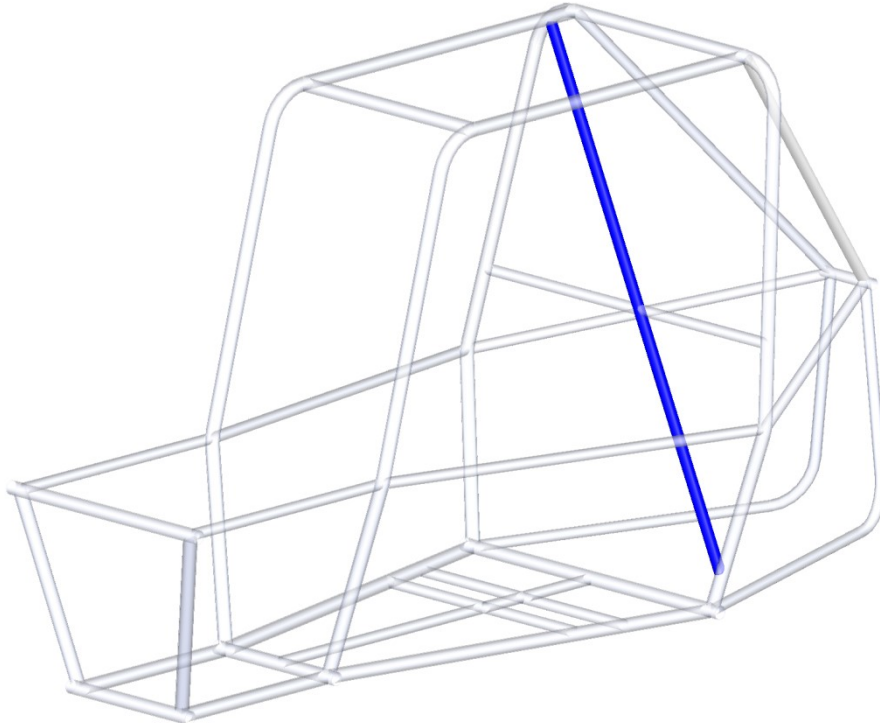

Figure B-14: Roll Cage, LDB

B.3.2.8 - RHO – Roll Hoop Overhead Members

The aft (rearward) ends of the RHO members intersect the RRH within 51 mm (2.0 in.) of Points BR and BL (defined by BLC). The forward ends of the RHO members, or the start of the bend between RHO and FBM define points CR and CL (Figure B-12). CLC, BLC and RHO members must all be coplanar. Out-of-plane bends at the aft (rearward) ends of the RHO members are not permitted. When a bend is used at Point CR/CL or BR/BL these points are defined at the start of the bend on the top-most plane of the Roll Cage, shown in Figure B-16: Roll Cage, Template Installation. When a bend is used at Point C, CLC must attach at or between the tangents of the bend, but shall not be further aft of the start of the bend.

The ends of the BLC define the location of points BL and BR. For cars constructed with bends at the top of the RRH, point B shall be on the inside end of the bend. Point B may not reside on the bend or a linear distance from the end of the bend.

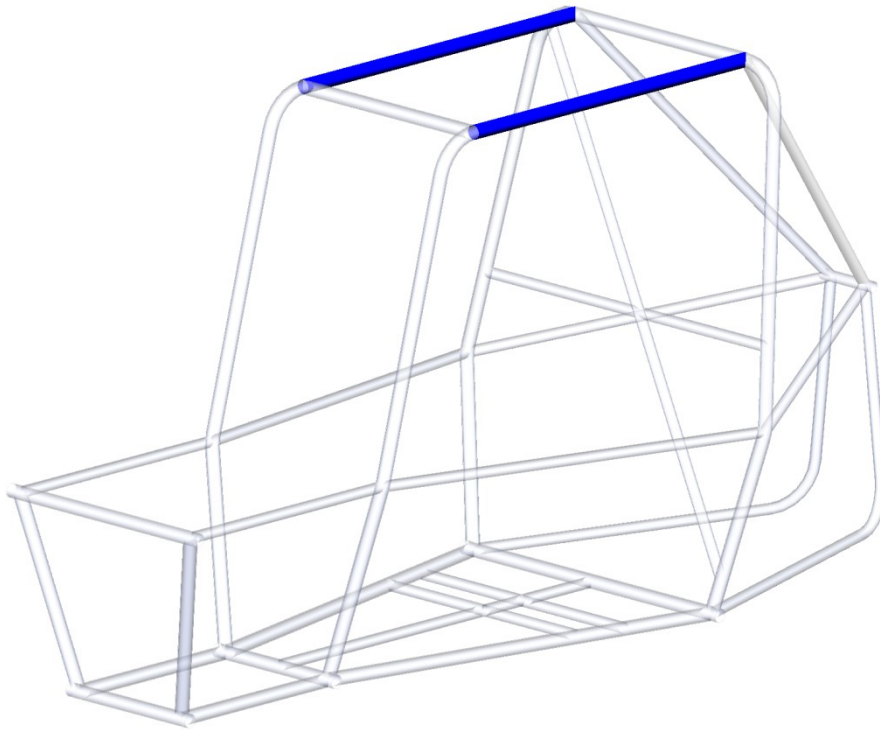

Figure B-15: Roll Cage, RHO

Points CR and CL must be between at least 305 mm (12 in.) forward of a point, in the vehicle's side view, defined by the intersection of the RHO members and a vertical line rising from the aft end of the seat bottom. This point on the seat is defined by the seat bottom intersection with a 101 mm (4 in.) radius circle which touches the seat bottom and the seat back. The top edge of the template is exactly horizontal with respect to gravity.

Points CR and CL and Points BR and BL must also be no lower than the top edge of the template, 1041.4 mm (41 in) above the seat and shall satisfy the Lateral Space requirements in Rule B.3.3.1 - Lateral Space.

Note: The top, longitudinal edge of the template shall be oriented exactly horizontal with respect to gravity.

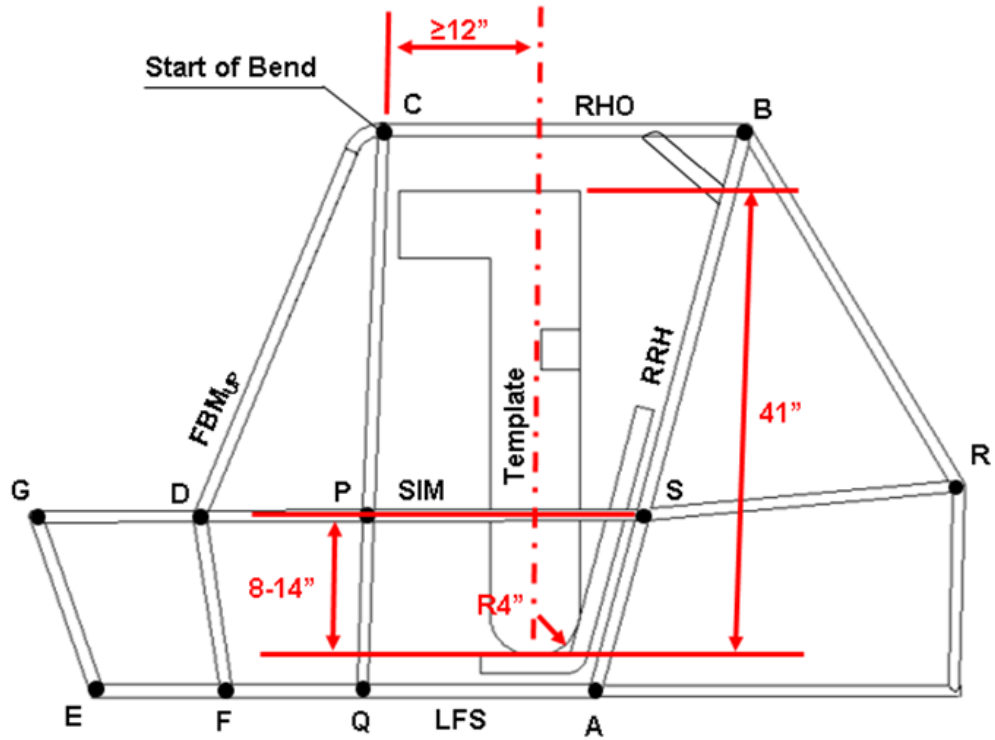

Figure B-16: Roll Cage, Template Installation

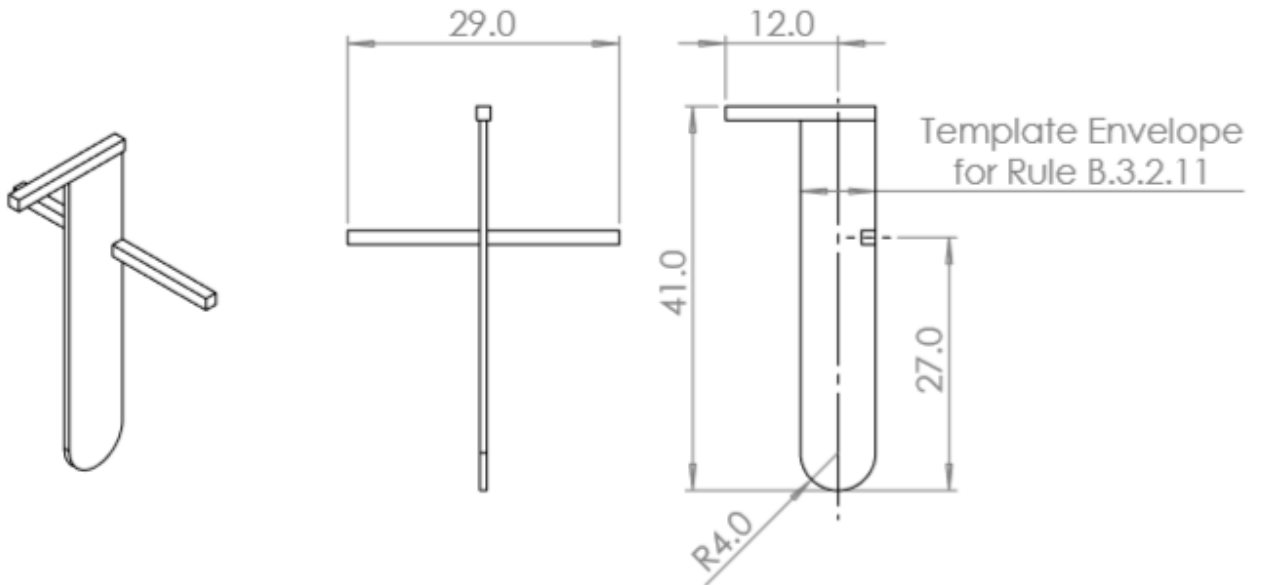

Figure B-17: Roll Cage Template Drawing

B.3.2.8.1 - Gussets for Lateral Clearance

Gussets may be added between the RHO and RRH to satisfy the requirements of Rule B.3.3.1 - Lateral Space. The added tubes shall be of primary material (B.3.2.16 - Roll Cage Materials).

Gusset tubes connecting the SIM to RRH or FBM for the purposes of satisfying the requirements of Rule B.3.3.1 - Lateral Space shall be of secondary material (B.3.2.3 - Secondary Members) and shall be closed in with Body Panels per Rule 0Body Panels. Gussets shall not interfere with the minimum radial clearance required around the fire extinguisher pull knob (Rule B.8.8.5 – Location and Clearance).

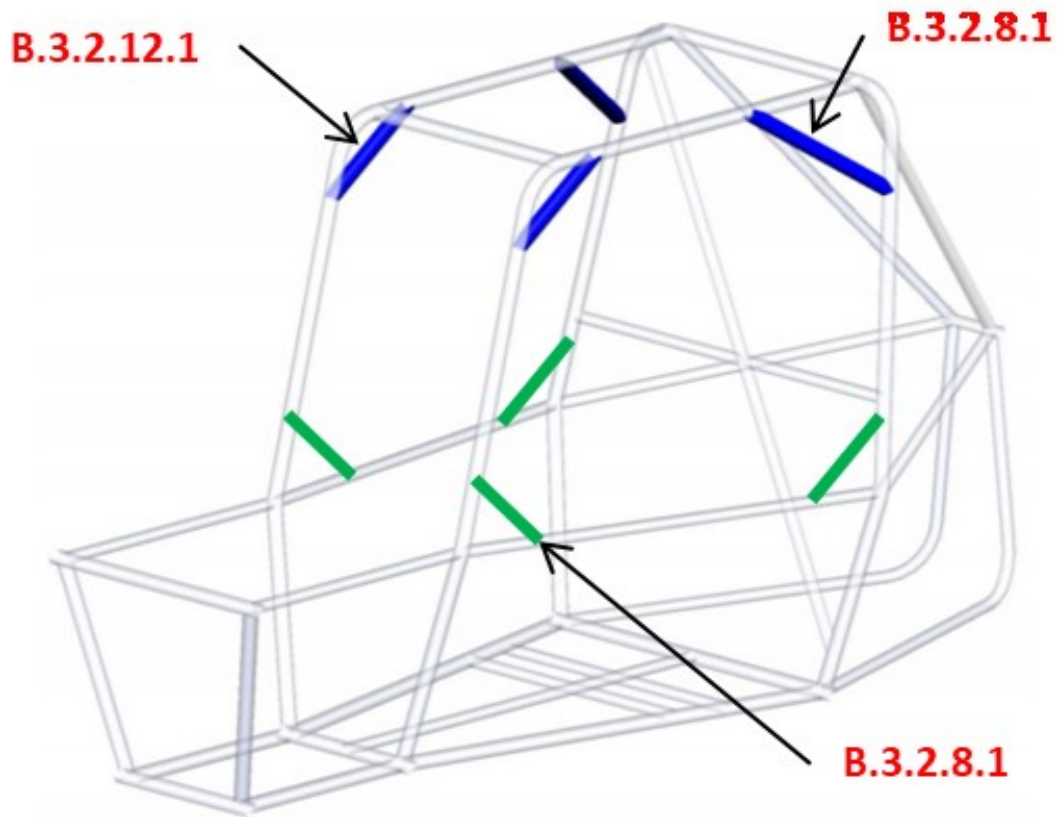

Figure B-18: Roll Cage, Gussets

B.3.2.9 - LFS – Lower Frame Side Members

The Lower Frame Side (LFS) members define the lower right and left edges of the roll cage. These members are joined to the bottom of the RRH at Point A and extend generally forward, to Point F, at least as far forward of every drivers' heels when seated in a normal driving position and actuating the pedals to their full extents. The forward ends of the LFS members are joined by a lateral cross member, FLC (Figure B-11). The intersection of the LFS members and the FLC define the points FR and FL. In 'Nose' designs, as shown in Figure B-18, the LFS shall extend forward to Point E, and is joined by lateral cross members FLC and ELC (Figure B-11). Alternative 'Nose' designs are feasible wherein Points E and F are co-located, provided adequate foot protection is achieved.

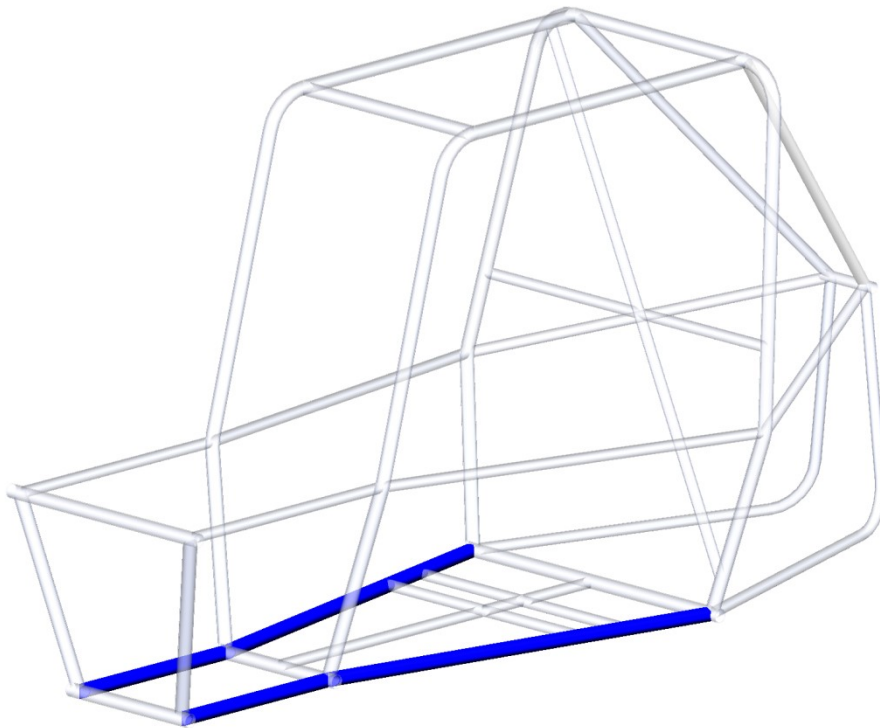

Figure B-19: Roll Cage 'Nose' Example, LFS

B.3.2.10 - SIM – Side Impact Members

The two Side Impact Members (SIM) define a horizontal mid-plane within the roll cage. These members are joined to the RRH, defining Point S, and extend forward, to a point at least as far forward of every drivers' toes when seated in a normal driving position. The forward ends of the SIM members shall intersect with the FBM, defining Points DR and DL, this intersection shall be joined by a lateral crossmember, DLC. The SIM members must be between 203 mm (8 in.) and 356 mm (14 in.) above the inside seat bottom (Figure B-15) at all positions between points S and D. In 'Nose' designs, as shown in Figure B-19, the SIM extends forward to Points GR and GL, which shall be joined by a lateral cross member, GLC (Figure B-11). In this case, DLC may be omitted if GLC provides adequate protection for the driver's toes as noted below.

The feet of any driver must be entirely behind the plane defined by points FR/FL and DR/DL. If DLC is below the driver's toes, then an additional primary material Lateral Cross Member must run between the FBM members above the driver's toes.

Note: In 'Nose' designs, every drivers' feet must be entirely behind the plane defined by points GR/GL and ER/EL and below the plane defined by GR/GL and DR/DL. If GLC is below the driver's toes then an additional structure of secondary material shall be constructed between FBM, SIM and LC members above the driver's toes when viewed from both the front and side. This additional structure shall be entirely above the driver's toes and is not measured to the centerline of the tubes.

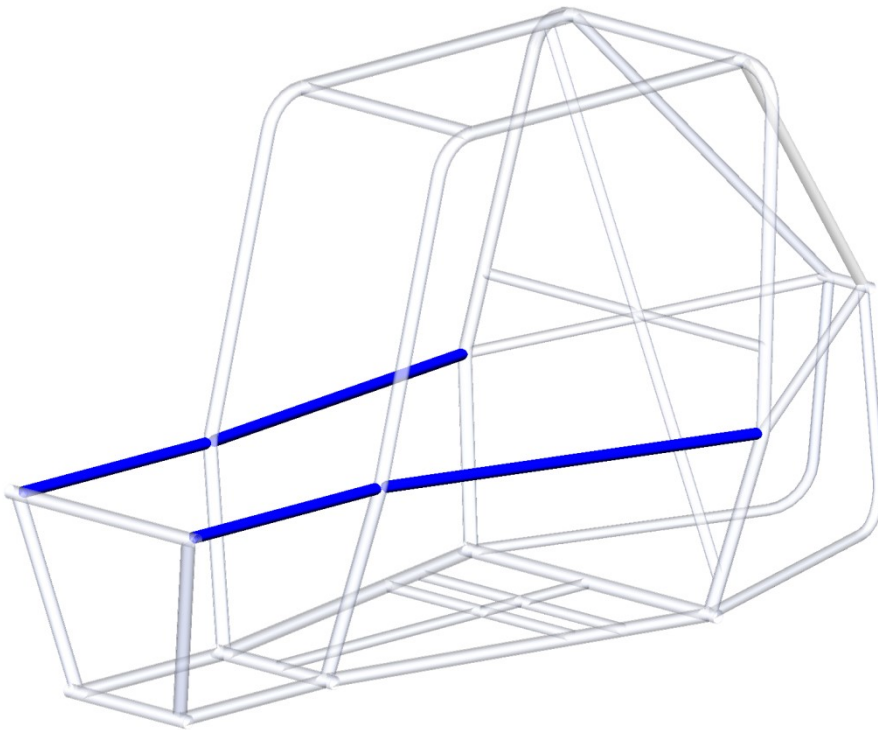

Figure B-20: Roll Cage 'Nose' Example, SIM

B.3.2.11 - UST – Under Seat Tubes

A secondary tube, or system of secondary tubes, shall pass underneath the seat, positioned in such a way to prevent the driver from passing through the plane of the LFS in the event of seat failure. The UST system shall connect to the LFS members on both sides of the roll cage.

The UST may also serve as the mounting location for the seat and/or the anti-submarine belts per B.4.5.3 - Seat Mounting Points and B.4.2.6.3 - Anti Submarine Belt Attachment.

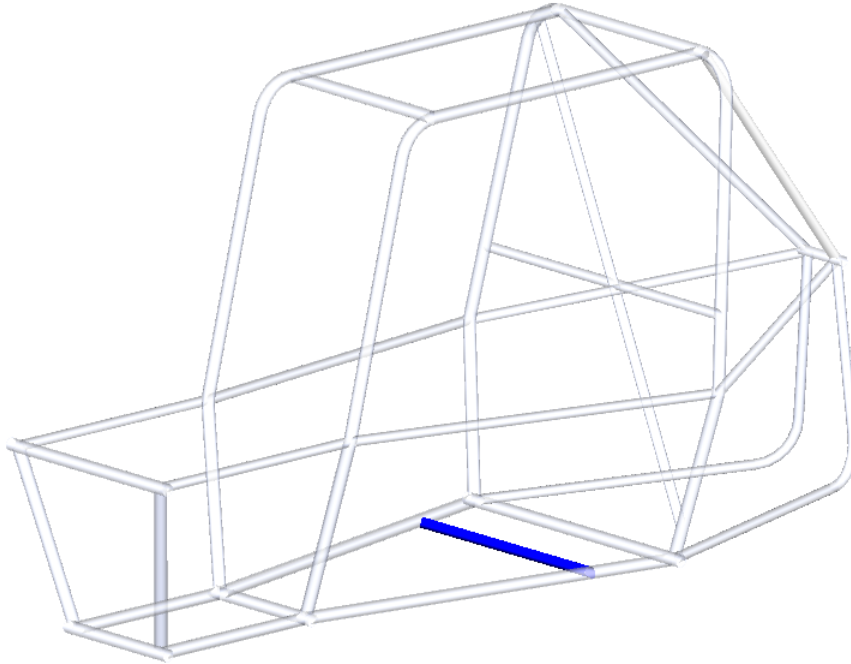

Figure B-21: Roll Cage 'Nose' Example, UST

B.3.2.12 - FBM – Front Bracing Members

Front Bracing Members shall join the RHO, SIM and LFS (Figure B-21) at Points C, D and F respectively. The upper Front Bracing Members (FBMUP) shall join Point C on the RHO to Point D on the SIM. It is preferred to notch the SIM around the FBM. The lower Front Bracing Members (FBMLOW) must join point D to point F. The FBMup and FBMlow shall each be continuous tubes. The angle between the FBMUP and the vertical must be less than or equal to 45 deg. If Front FAB, per Rule B.3.2.13.1 - Front Bracing, is used there is no angle requirement between FBM and vertical.

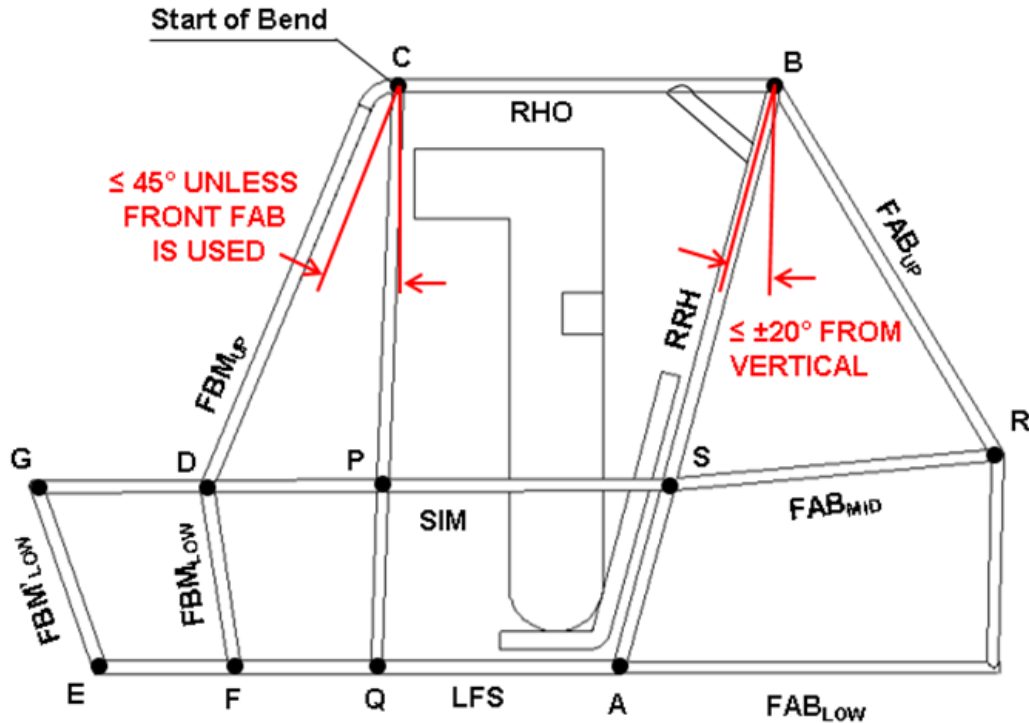

Figure B-22: Roll Cage, FBM

B.3.2.12.1 - Gussets for RHO and FBM

If the RHO and FBM on one side of the vehicle are not comprised jointly of one tube, bent at point C, then a gusset is required at point C to support the joint between the RHO and the FBM. The total weld length of the gusset must be two times the tubing circumference (of the primary material). Thus, if a tube is used to brace the FBM and RHO, it must be primary material. Plate gussets may be used if the thickness of the material meets or exceeds that of the primary material used. Figure B-23: RHO / FBM Gussets

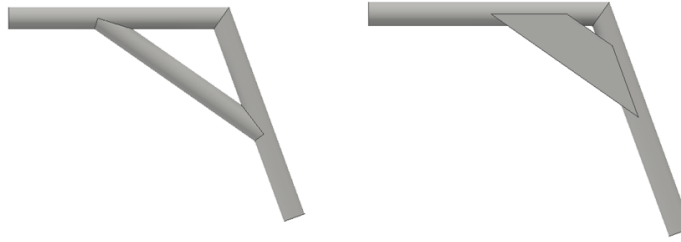

Figure B-23: RHO / FBM Gussets

B.3.2.13 - FAB – Fore - Aft Bracing

The RRH shall be restrained from rotation and bending in the side view by a system of triangulated bracing. Triangulation angles (projected to the side view) must be at least 20 deg. between members. Bracing shall either be front bracing or rear bracing (FAB), a better design will result if both front and rear bracing are incorporated:

Rear Bracing - directly restrain both Points B from longitudinal displacement in the event of failure of the joints at Points C; or

Front Bracing - restrain both Points C from longitudinal and vertical displacement, thus supporting Points B through the RHO members.

B.3.2.13.1 - Front Bracing

Front Bracing systems shall connect the FBMUP to the SIM, on the same sides. The intersection with the FBMUP members shall be within 127 mm (5 in.) measured as a straight-line distance from centerline to centerline of Point C. The intersection with the SIM members defines Point P which shall be vertically supported by further members extending from Point P to the LFS members, which defines Point Q. Points P and Q exist only with complete Front Bracing.

B.3.2.13.2 - Rear Bracing

Rear Bracing systems shall create a structural triangle, in the side view, on each side of the vehicle. Each triangle shall be aft of the RRH, include the RRH as a vertical element, have one vertex at Point B, and one vertex at either Point S or Point A. The members forming this structural triangle shall be continuous and comply with Rule B.3.2.1. The third (aft) vertex of each triangle, Point R (Figure B-23), shall additionally be connected to Point S or A, whichever is not part of the structural triangle. This additional connection is considered part of a complete FAB system, and is not subject to B.3.2.1 - Member Requirements, and may be formed using multiple joined members which may encompass a bend of greater than 30 deg.

Attachment of rear FAB system shall be within 51 mm (2 in) of Point B, Point S and Point A, on each side of the vehicle. Members connecting to Point A shall attach at an angle of 45 degrees or greater as measured from the ALC. Distances are measured in a straight-line from centerline to centerline of the tube intersections. The aft vertex of each rear bracing triangle defines Point R and shall be joined by a lateral crossmember, RLC, per B.3.2.5 - LC – Lateral Cross Member.

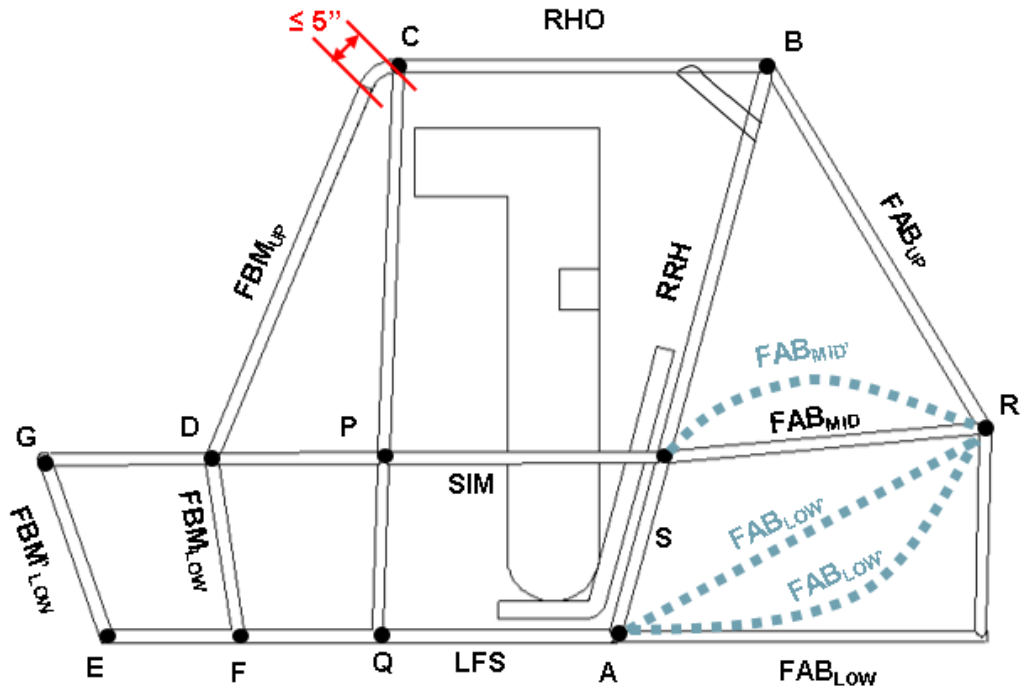

Figure B-24: Roll Cage, FAB

B.3.2.14 - Butt Joints

B.3.2.14.1 - Requirement

Many roll cage members are required to be continuous tubes and may not be made of multiple pieces. Roll cage members which are made of multiple tubes, joined by welding in a butt joint, shall be reinforced with an internal sleeve. Tubes which are joined at an angle greater than 5 deg. need not be sleeved; angles of less than 5 deg. will be considered butt joints.

B.3.2.14.2 - Size

Sleeves shall be designed to fit tightly inside the joint being reinforced. External sleeves are not allowed. Sleeves shall extend into each side of the butt joint, a length of at least two times the diameter of the tubes being reinforced and shall be made from steel at least as thick as the tubes being reinforced.

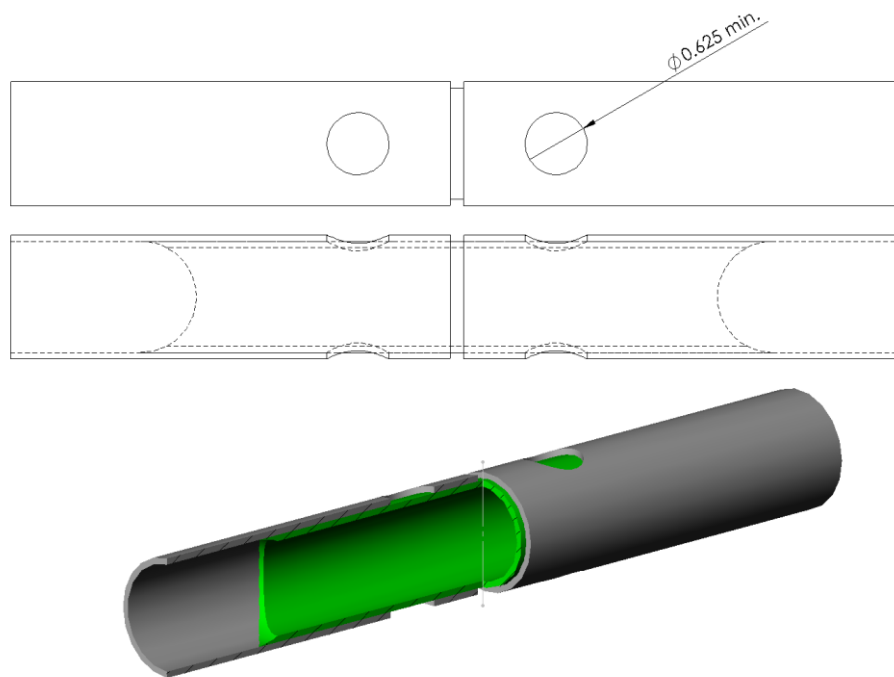

Figure B-25: Roll Cage, Butt Joint Sleeve

B.3.2.14.3 - Welding

The general arrangement of an acceptable sleeved joint is shown in Figure B-25. A butt weld and four (4) rosette welds are required. Two (2) rosette welds are required on each tube piece. Rosette welds are to be made in holes of a minimum diameter of 16 mm (0.625 in.).

A minimum of 102 mm (4.0 in.) of linear weld is required to secure the sleeve inside the joint, including the butt joint and the rosette welds.

B.3.2.15 - Welding Process Check

Prior to welding any joint on any of the vehicle's roll cage elements, each person shall individually complete two welding samples, defined below, using the same primary materials and processes as used in the roll cage element welds. All welding samples shall be submitted at Technical Inspection. Vehicles for which complete sets of welding samples are not submitted, or for which any of the welding samples are judged inadequate, will not be allowed to compete in dynamic or endurance events.

Welding samples shall be made from the same tube material, diameter, and thickness as the welds made by each person on the primary roll cage elements. For information on best practices for weld samples, see www.bajasae.net/go/downloads.

All weld samples shall be indelibly marked, by permanent means such as engraving, etching, or stamping with all the following information:

- School Name or School Initials
- Welder Name or Welder Initials
- Date of construction of weld sample

Sample 1 – Destructive Testing:

The sample shall comprise a 90-degree joint, the leg length of which is unrestricted shall be (Figure B-26) be destructively tested. Passing samples will exhibit a joint failure in the base material and not in the weld metal. The testing method is free and either tensile or bending failure may be induced; however, the peak stress must be located at the weld. In the case of bending failure, take care that the largest bending moment is located at the weld. **Samples shall be tested prior to arrival at competition, and both pieces presented for inspection in the case of complete separation during testing.**

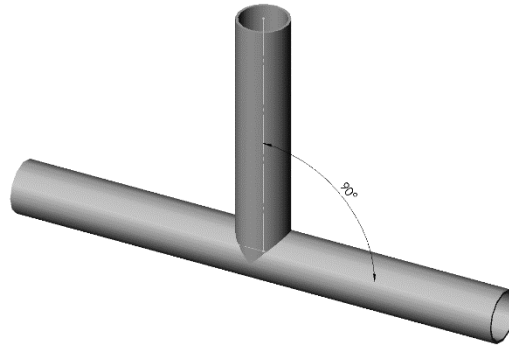

Figure B-26: Roll Cage, Welding Sample 1

Sample 2 – Destructive Inspection

The sample shall comprise of two tubes joined at a 30-degree angle with a length of at least 150 mm (5.9 in.) from the center of the joint (Figure B-27) to the end of each extended leg. The sample shall be sectioned along the length of tube to reveal adequate and uniform weld penetration (Figure B-27). **Samples shall be tested prior to arrival at competition, and both pieces presented for inspection in the case of complete separation during testing.**

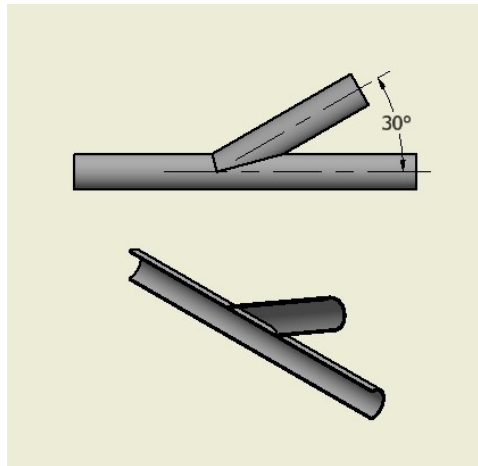

Figure B-27: Roll Cage, Welding Sample 2

B.3.2.16 - Roll Cage Materials

The material used for the Primary Roll Cage Members and bracing must meet one of the following requirements:

- Circular steel tubing with an outside diameter of 25 mm (0.984 in) and a wall thickness of 3 mm (0.118 in.) and a carbon content of at least 0.18%.

- A steel shape with bending stiffness and bending strength exceeding that of circular steel tubing with an outside diameter of 25 mm (0.984 in.) and a wall thickness of 3 mm (0.118 in.). The wall thickness must be at least 1.57 mm (0.062 in.) and the carbon content must be at least 0.18%, regardless of material or section size. The bending stiffness and bending strength must be calculated about a neutral axis that gives the minimum values.

Note : Docol R8 tubing is permitted without the required carbon content, provided the aforementioned dimensional requirements or equivalencies are met. This material is not intended to undergo any heat treatment after welding and sizing as this may alter the mechanical properties of the material.

Bending stiffness, k_b , is given by:

$$k_b = EI$$

Where:

E - Modulus of elasticity (205 GPa for all steels)

I - Second moment of area for the structural cross section

Bending strength, S_b , is given by:

$$S_b = \frac{S_y I}{c}$$

Where:

S_y - Yield strength (365 MPa for 1018 steel)

c - Distance from neutral axis to extreme fiber

Documentation of the equivalency must include:

- 1) Typed calculations to be presented at Technical Inspection which proves sufficient bending stiffness and bending strength. All calculations must be in SI units, to three significant figures to the nominal tube sizes as specified by the invoice. Teams shall show figures for 1018 steel and the substitute material.
- 2) Invoices of the roll cage materials. These invoices must be dated within 5 years of Jan 1 of the competition year.
- 3) Material tests or certifications, which specify the carbon content and yield strength. These tests or certifications should be dated within 5 years of Jan 1 of the competition year.

B.3.2.17 - Roll Cage Specification Sheet

Each vehicle must present a completed and signed Baja SAE® Roll Cage Specification Sheet at Technical Inspection. Newly completed copies must be presented for each competition.

B.3.3 - Driver Clearance

B.3.3.1 - Lateral Space

Minimum space is based on clearances between the driver and a straight edge applied to any two points on the outside edge of the roll cage structure. The driver's helmet shall have 152 mm (6 in.) clearance, while the driver's shoulders, torso, hips, thighs, knees, arms, elbows, and hands shall have 76 mm (3 in.) clearance. Clearances are relative to any and all drivers selected at technical inspection, seated in a normal driving position, and wearing all required equipment.

For any member to contribute to lateral clearance, that member must be listed in B.3.2.2 Primary Members, B.3.2.3 - Secondary Members, or conform to the requirements of B.3.8.2.1 - Gussets for Lateral Clearance or B.3.2.12.1 Gussets for RHO and FBM, otherwise it is assumed to have no contribution (Suspension members, for example, do not contribute to lateral spacing).

B.3.3.2 - Vertical Space

The driver's helmet shall have 152 mm (6 in.) minimum clearance from any two points among those members that make up to top of the roll cage. These members are: the RHO members (exclusive of any covering or padding); the RRH upper, LC; and the LC between points C (left and right). In an elevation (side) view, no part of the driver's body, shoes, and clothing may extend beyond the envelope of the roll cage.

B.3.4 - Sharp Edges

The entire vehicle, including the frame, shall have no exposed sharp edges which might endanger the driver, track workers, or people working around the vehicle while the vehicle is in any attitude (static, dynamic, inverted, etc.).

B.3.5 - Bolted Roll Cages

Bolted Roll cages joints are acceptable only if the following requirements are met (Figure B-28):

- 1) Flanges or tabs must be twice (2x) the thickness of the member and made of the same material. They must be properly welded to each tubing part to be joined. The face of the flange must be perpendicular to the axis of the member.
- 2) The radius of the flange must be at least 25 mm (1.0 in.) larger than the outer radius of the member.
- 3) The gap between faces of the flanges (before being tightened) must be no greater than 0.07 mm (0.003 in).
- 4) The flanges must be attached with at least 3 bolts with a minimum diameter of 8 mm (0.313 in.), equally spaced on the flanges. The minimum edge distance between the bolt holes and the edge of the flanges must be twice the bolt diameter.
- 5) Pin Joints are not permitted.

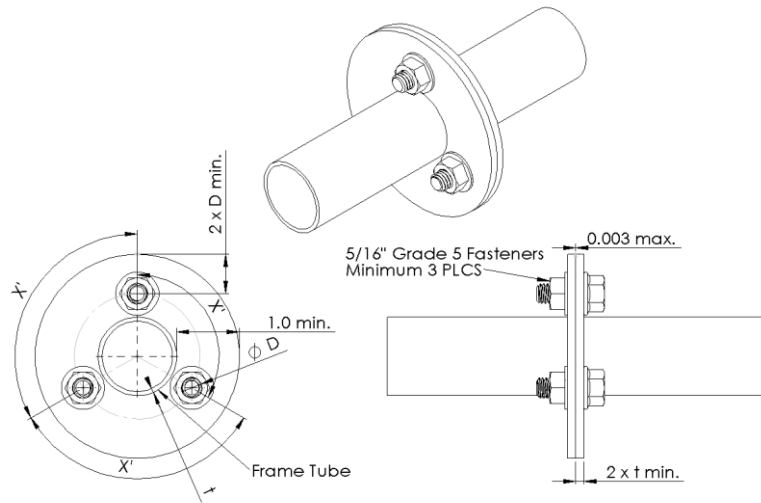

Figure B-28: Roll Cage, Required Joint for Removable Members

B.3.6 - Drilled Members

B.3.6.1 - Sleeved Joints

Members which need to be drilled through both walls for the purpose of mounting fasteners or routing accessories shall be reinforced with a weld-in sleeve. Sleeves shall be designed to fit tightly on the inside of the hole or joint being reinforced as well as the fastener passing through the sleeve. Sleeves shall extend beyond the tube on both sides and be fully welded to the tube. An unacceptable joint is denoted by a red “X”. An acceptable joint is denoted by a green “O” in Figure B-28.

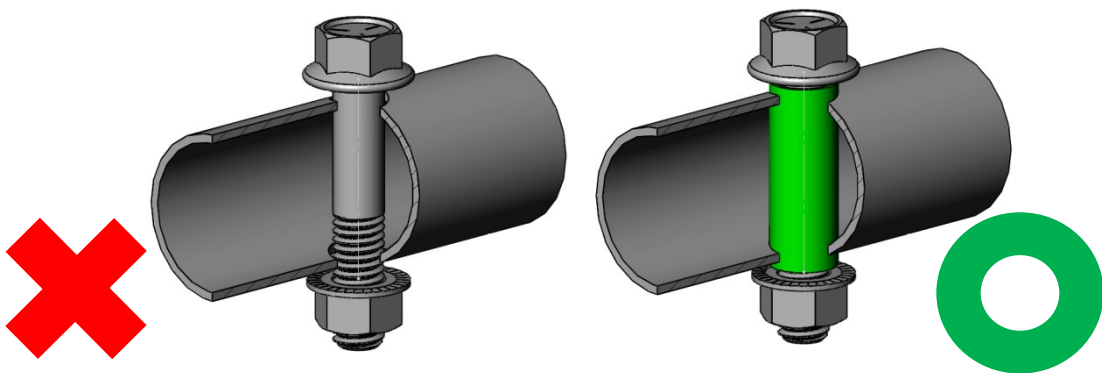

Figure B-29: Roll Cage, Required sleeve for drilled holes

B.3.6.2 - Drilled Holes

Single drilled holes in members with a diameter less than or equal to 5 mm (0.197 in) do not require a sleeve.

B.3.7 - Roll Cage Documentation Package

B.3.7.1 - Required Documents

Required documents for the Roll Cage Documentation Package include: Roll Cage Specification Sheet & material documentation (invoices, certifications, calculations, etc.) and a single isometric view diagram of the frame highlighting professional fabrication.

B.3.7.2 - Document Submittal

- 1) Download the form and template from bajasae.net download section (Note: All files that are uploaded must be in a PDF format)
- 2) Upload the Roll Cage Documentation Package (max size 5 MB)
 - a. Roll Cage Specification Sheet
 - b. Invoice of roll cage material
 - c. Material Test of Certification
 - d. Any Required Calculation per rule B.3.2.16 - Roll Cage Materials
 - e. A diagram highlighting any parts of the frame that were outsourced or professionally fabricated

B.3.7.3 - Process

Documents will be reviewed by the National Technical Inspectors on a first come first serve basis. Typical review period will be 30 days after the deadline. After review, feedback will be given to teams. If the submission is rejected by the National Technical Inspectors, the team must correct the error noted in the rejection and continue to resubmit the Roll Cage Documentation Package, until they are marked Accepted. It is the responsibility of teams to submit complete documents by the appropriate deadlines. If teams have additional questions, they will need to use other resources to find the answers or wait until competition.

Note: If a team's initial Roll Cage Documentation Package is received more than five (5) days late it will be classified as "Not Submitted" and your team will be removed (withdrawn) from the event. Teams will not be removed from the event for receiving a rejected judgement.

Article 4 - Driver Restraint

B.4.1 - Function

The driver restraint system shall function to safely and securely hold the driver within the envelope of the vehicle's roll cage. The driver restraint system shall also quickly and completely disengage when required to allow the driver a minimum egress time. The driver restraint system consists of a safety harness, arm restraints, and the vehicle's seat. The driver restraint system shall be fully functional and properly worn whenever the driver is seated in the vehicle.

B.4.2 - Driver Harness

The driver harness shall consist of a 5-point (or more) system comprised of two shoulder belts (left and right), two lap belts (left and right), and one or more anti-submarine belts all joining at a single, central buckle (disconnect point). The anti-submarine belt serves to positively locate the buckle and prevent the driver from riding under the lap belts.

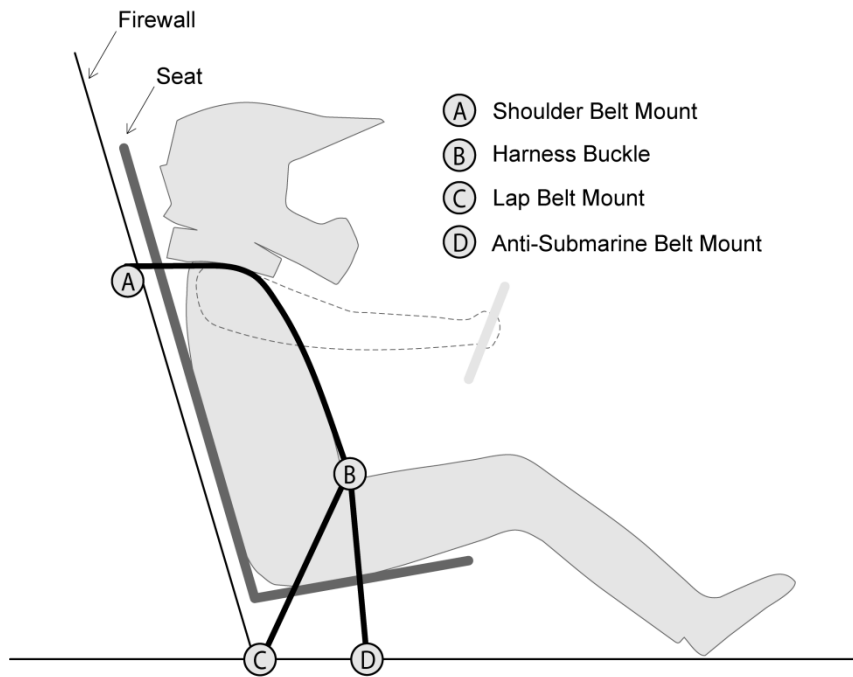

Figure B-30: Driver Harness Schematic

B.4.2.1 - Certification

All driver restraint systems shall meet either SFI Specification 16.5/16.1, or FIA specification 8853/98. The material of shoulder and lap belts shall be of Nylon or Dacron polyester and in new or like-new condition, 76 mm (3.0 in.) in width, and free from injurious defects. Anti-submarine belts shall meet the same conditions, but have a minimum nominal width of 51 mm (2.0 in.).

Note: Some 2.0 inch anti-submarine belts measure 1.75 in. actual minimum width, and are acceptable for use.

B.4.2.2 - Expiration

In December of 2016, SFI updated the design and format of driver harness expiration tags. Manufacturers are permitted to use old tags until their supply runs out. Baja SAE® permits the use of driver harnesses with the old and the new tag design, provided:

For old style tags: On January 1st of the competition year, harnesses shall be no more than three (3) years old.

For new style tags: Harnesses with expiration tags bearing a “Valid Until” date that is on or after the last day of the current competition.



Figure B-31: Driver Harness, SFI Tag, Old Style (Left), New Style (Right)

B.4.2.3 - Release Mechanism

All belts in the driver harness must join to a single, central, metal-to-metal, lever-type, quick-release buckle. Cam-Lock, and other enclosed buckles susceptible to jamming from small debris (such as sand particles) are explicitly prohibited. The release mechanism (buckle) shall be protected against accidental unfastening from a direct pull, rollover or slide along the side.

B.4.2.4 - Shoulder Belts

The shoulder harness shall be of the over-the-shoulder type. Only separate shoulder straps are permitted. “Y”-type shoulder straps are explicitly prohibited.

B.4.2.4.1 - Positioning, Vertical

The shoulder belt mounting point (A) (see Figure B-32) shall be positioned no higher than vertically level with each driver’s shoulders, and no lower than 102 mm (4.0 in.) vertically below each driver’s shoulders.

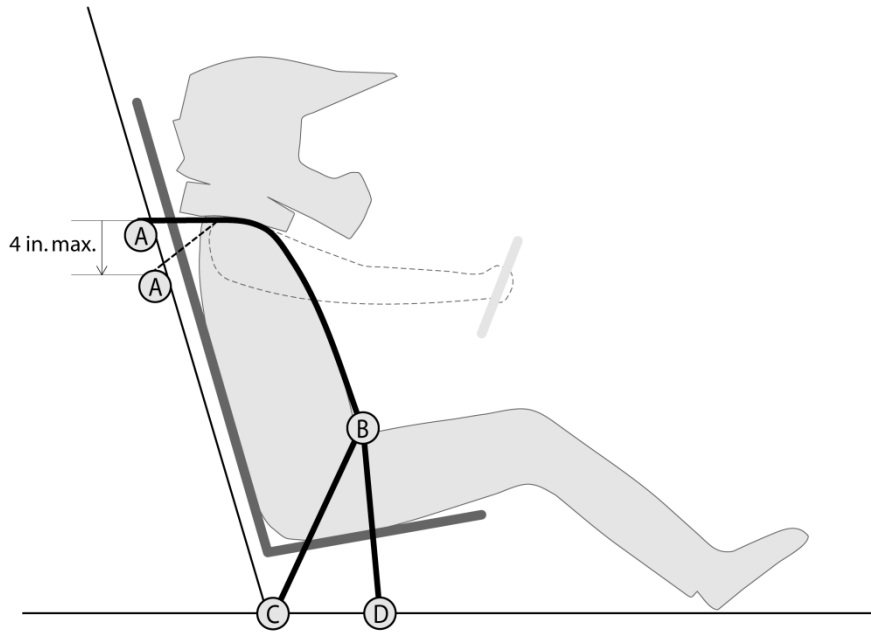

Figure B-32: Driver Harness, Shoulder Harness Vertical Position

B.4.2.4.2 - Positioning, Lateral

The lateral spacing of the shoulder belts shall be between 152 mm (6.0 in.) and 229 mm (9.0 in.) when measured center-to-center. See Figure B-33.

Lateral position of the shoulder belts along their mounting tube must be restrained by a structure other than the firewall.

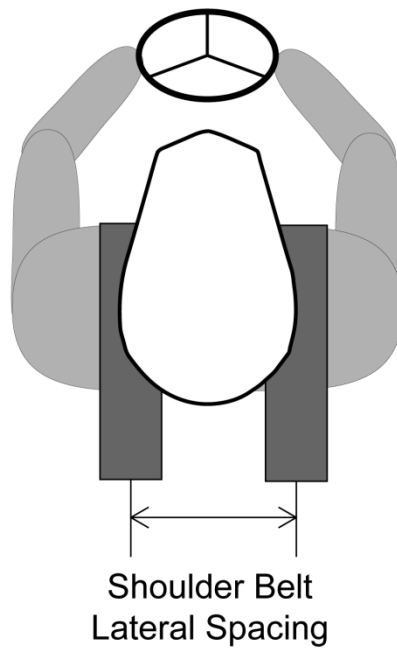

Figure B-33: Driver Harness, Shoulder Harness Lateral Position

B.4.2.4.3 - Attachment

The shoulder belts shall be looped and secured around a straight, horizontal tube welded within the plane of the RRH. The tube that the shoulder belts are looped around shall meet the requirements of a secondary member, B.3.2.3 - Secondary Members. Provisions for lateral position restraint shall be provided. Firewall material is not acceptable for lateral position restraint. See Figure B-34 for details.



Figure B-34: Driver Harness, Shoulder Harness Lateral Restraint

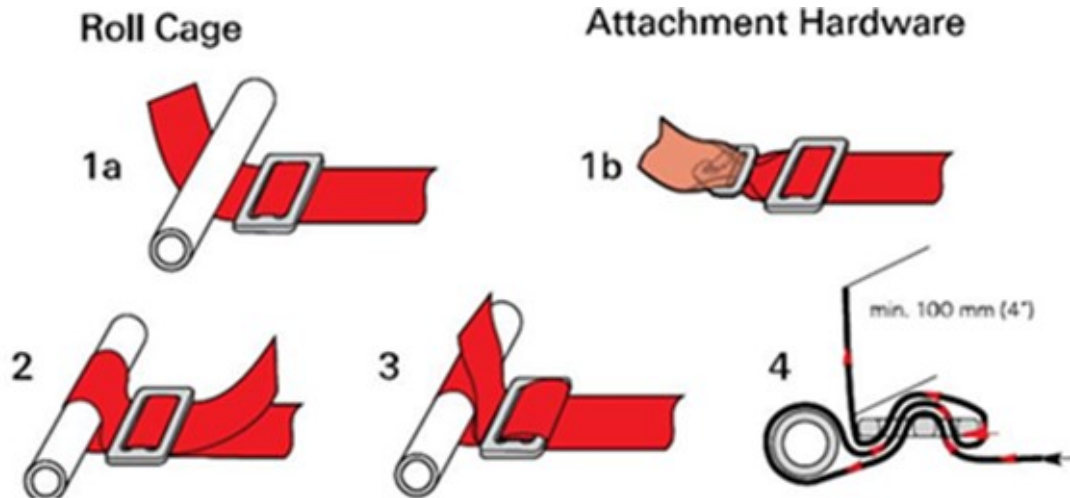

Figure B-35: Driver Harness, Diagram of Proper Wrapping of Webbing

B.4.2.4.4 - Redirection

The shoulder belts must run directly from their mountings to the driver's shoulders, without redirection by any part of the vehicle or its equipment, including seats.

Webbing shall not be twisted or rotated at any point along the path of the shoulder belt.

B.4.2.4.5 - Adjustment

The shoulder belts shall be in proper adjustment for the driver at all times. When the driver harness is worn, each buckle or adjuster in the system shall have excess adjustment capacity to fit all drivers. The minimum length of excess shoulder harness webbing is 102 mm (4.0 in). See Figure B-35.

B.4.2.4.6 - Protection

The shoulder belts shall be protected from potential damage from aft of the RRH. The firewall must protect the shoulder belts. The firewall may be pocketed or extended to facilitate this requirement, as long as no open gaps result. Excess shoulder belt webbing shall be neatly contained and kept within the roll envelope of the vehicle.

B.4.2.5 - Lap Belts

The lap belt halves must run directly from the buckle, over the driver's hips and to their mounting points without redirection by any part of the vehicle or its equipment (including the seat). The lap belt halves must be mounted to frame tabs using the bracket supplied with the safety harness. Lap belts may not be mounted by wrapping around tubes.

B.4.2.5.1 - Positioning

The lap belt (point B to point C) in Figure B-36 shall be positioned such that it passes over the driver's pelvic area below the Anterior Superior Iliac Spines (the hip bones). The lap belt shall not be worn over the driver's intestines or abdomen.

In a side view, the lap belt must be at a minor angle (angle "L" or angle BCD) of between 45 deg and 80 deg to the horizontal. This requirement means that the centerline of the lap belt at the seat bottom will be approximately 76 mm (3.0 in.) forward of the bottom of the seat back.

Note: Quick disconnect fasteners for body panels are recommended, and facilitate a faster technical inspection process.

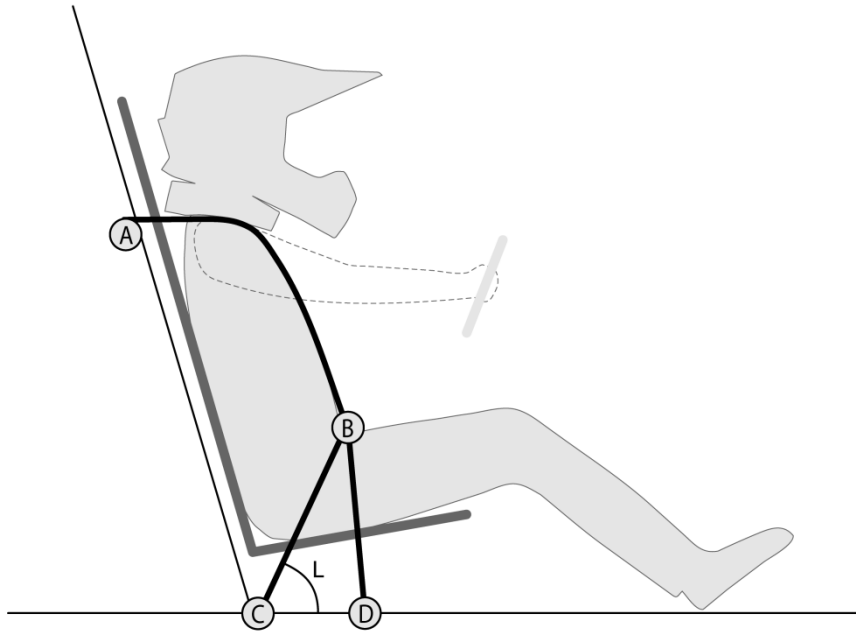

Figure B-36: Driver Harness, Lap Belt Angle

B.4.2.5.2 - Attachment

The lap belts shall be securely attached to the vehicle frame with threaded fasteners and metal tabs meeting the requirements of B.12.2 - Required Attachment Tabs. Webbing shall be routed through buckles per Figure B-35. The frame lap belt tabs shall be installed such that the lap belt tabs pivot freely and are not loaded in bending.

Lap belts wrapped around tubes or secured with eye-bolts and/or eye-bolt hardware are explicitly prohibited.

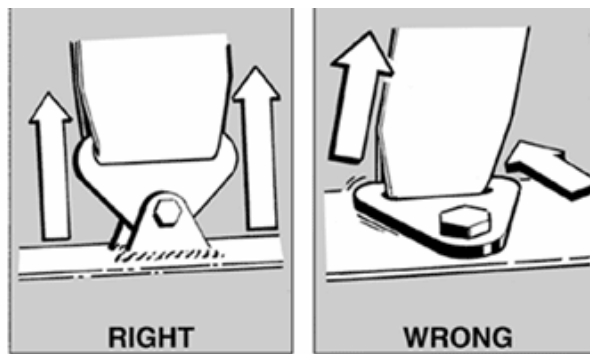

Figure B-37: Driver Harness, Lap Belt Tab Orientation

B.4.2.5.3 - Redirection

The lap belts shall be routed directly from the mounting points over the driver's hips and to the release mechanism (buckle) without redirection by any part of the vehicle or its equipment (including the seat).

Webbing shall not be twisted or rotated at any point along the path of the lap belt.

B.4.2.5.4 - Adjustment

The lap belts shall be in proper adjustment for the driver at all times. When the driver harness is worn, each buckle or adjuster in the system shall have excess adjustment capacity. The minimum length of excess lap belt webbing is 102 mm (4.0 in). See Figure B-35.

B.4.2.5.5 - Protection

The lap belts shall be protected from potential damage by the vehicle's body panels. Excess lap belt webbing shall be neatly contained and kept within the roll envelope of the vehicle.

B.4.2.6 - Anti-Submarine Belts

B.4.2.6.1 - Number of Points

The anti-submarine belt (Line BD in Figure B-38) shall be at least a single-point mount (a 5-point driver harness configuration). Driver harnesses of the 6-point and 7-point types are permitted. A 6-point system utilizes two anti-submarine belt mounting points. A 7-point system utilizes three anti-submarine belt mounting points.

B.4.2.6.2 - Positioning

Anti-submarine belts shall be mounted to the vehicle frame at a point aft of the chest line as denoted by a positive angle "S" in Figure B-38. The anti-submarine belt mounting point shall be forward of the lap belt mounting points. The chest line passes through point B and is parallel to the driver's sternum. The anti-submarine belt angle (angle S) is suggested to be 20 deg. The anti-submarine belt shall be mounted either to a frame tab or wrapped around a frame member meeting at least secondary member requirements.

6-point and 7-point harnesses shall be installed per the manufacturer's instructions. Teams shall be prepared to provide documentation of mounting instructions to NTI at the time of technical inspection.

Note: Quick disconnect fasteners for body panels are recommended, and facilitate a faster technical inspection process.

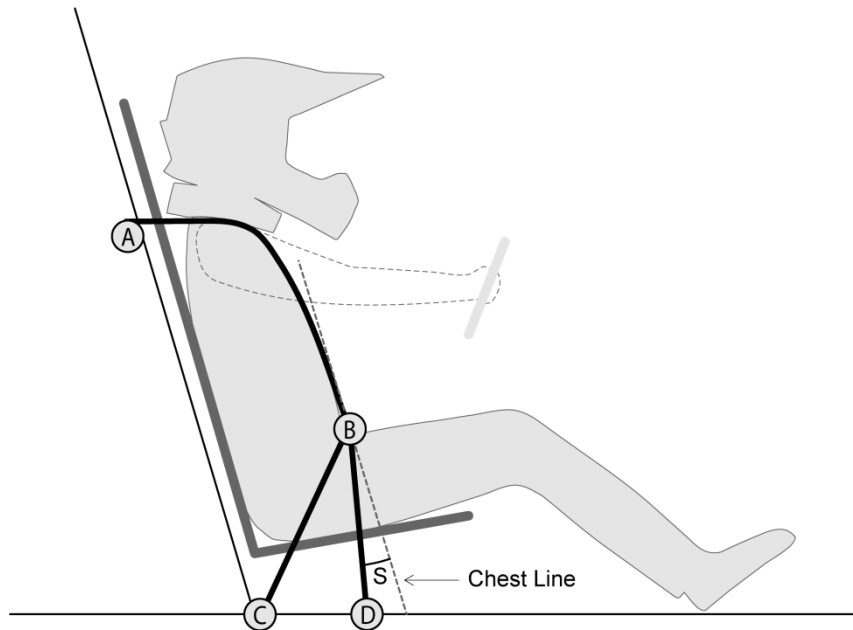

Figure B-38: Driver Harness, Anti-Submarine Belt Angle

B.4.2.6.3 - Attachment

The anti-submarine belts shall be securely attached to the vehicle frame by one of the following methods:

- a. Metal tabs joined by a threaded fastener.
- b. Webbing wrapped around a frame member
- c. Webbing wrapped around a bolt secured by metal tabs in double shear.

Anti-submarine belts secured with eye-bolts are explicitly prohibited. Webbing shall be wrapped per Figure B-35: Driver Harness, Diagram of Proper Wrapping of Webbing.

Any threaded fastener in the driver restraint system shall meet the requirements of Part B : Article 12 - Fasteners

The frame tabs which accept the metal anti-submarine belt tabs or bolt in method "a" or "c" shall meet the following requirements of B.12.2 - Required Attachment Tabs.

If the anti-submarine belt is wrapped around a frame member (method "b") or a bolt (method "c"), the following requirements shall be met:

- a. The anti-submarine belt mounting tube shall have features designed to limit total lateral movement to 25.4 mm (1.0 in.) or less.
- b. The anti-submarine belt webbing shall be protected from sharp edges such as bolt threads, tab edges, and
- c. The anti-submarine belt mounting tube or tube holding tabs shall meet the frame requirements of a secondary member. The mounting tube may be constructed of a single tube with bends, or may be constructed with no more than three tubes and two mitered joints (excluding connections to the LFS). The anti-submarine belt mounting tube shall join both of the vehicle's LFS members

and be oriented parallel to the LC's. The mounting tube may not be cantilevered off of another tube creating an undue bending moment.

B.4.2.6.4 - Redirection

Redirection of the anti-submarine belt by a rigid frame, seat member, or seat edge is allowed. Redirected belt webbing must not contain a bend of more than 30 deg (Figure B-39). The redirecting member or edge must be designed to prevent chaffing or abrasion of the belt webbing.

Webbing shall not be twisted at any point along the path of the anti-submarine belt.

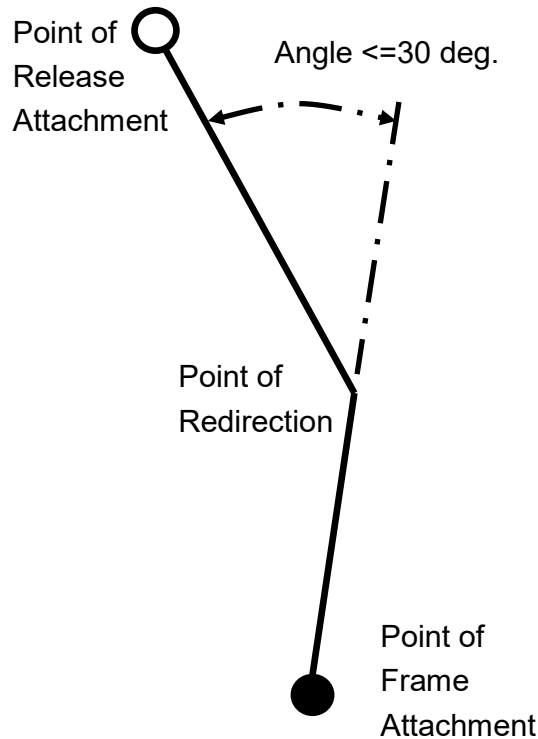

Figure B-39: Driver Harness, Anti-Submarine Belt Redirection

B.4.2.6.5 - Adjustment

The anti-submarine belts shall be in proper adjustment for the driver at all times. When the driver harness is worn, each buckle or adjuster in the system shall have excess adjustment capacity.

B.4.2.6.6 - Protection

All anti-submarine belts shall be protected by the vehicle skid plate. Excess anti-submarine belt webbing shall be neatly contained and kept within the roll envelope of the vehicle.

B.4.3 - Arm Restraints

In the event of a rollover, the driver's arms must be kept within the limits of the roll cage space (B.3.3.1 - Lateral Space) by use of arm restraints. Arm restraints must be securely fastened to the driver restraint system. Only commercially available arm restraints meeting SFI 3.3 are allowed. Left and right arm restraints must separate, individual pieces, independently connect to the safety belts.

B.4.3.1 - Condition

The restraints must be in overall good condition and show no signs of wear, no cuts, fretting, chafing or wear. The restraints must bear the appropriate labels.



Figure B-40: Driver Harness, Arm Restraints

B.4.3.2 - Expiration

Arm restraint expiration dates are not required.

B.4.3.3 - Positioning

Arm restraints must be installed such that the driver can release the harness and exit the vehicle unassisted, regardless of the vehicle's position. The arm restraint must be worn by the driver on the forearm just below the elbow. The driver must be able to reach the cockpit kill switch and steering wheel, but not allow their arms to exit the cockpit.

B.4.3.4 - Attachment

Arm restraints shall be attached to the buckle of the driver harness when assembled.

B.4.4 - Head Restraint

A head restraint must be provided to limit rearward motion of the driver's head from a normal driving position. The head restraint must be mechanically fastened to the vehicle, preferably to the vehicle frame. Hook-and-loop and adhesive methods are prohibited. Head restraints may also be mechanically fastened or integral to the driver's seat.

Caution: HANS devices and Leatt braces are not allowed due to the improper fitment of these devices with respect to nominal Baja SAE® seat design and seating position.

B.4.5 - Seats

The seat shall work in concert with the driver harness to secure the driver within the envelope of the roll cage. Seats shall be of conventional design. See details below. All seats shall be designed for the upright seating position. Suspension seats are prohibited. The upright seating position is defined by the angle of the driver's back to a horizontal line. The seat back angle (Figure B-41) for an upright seating position is greater than 65 deg. As a reference, a completely upright driver will have a back angle of 90 deg.

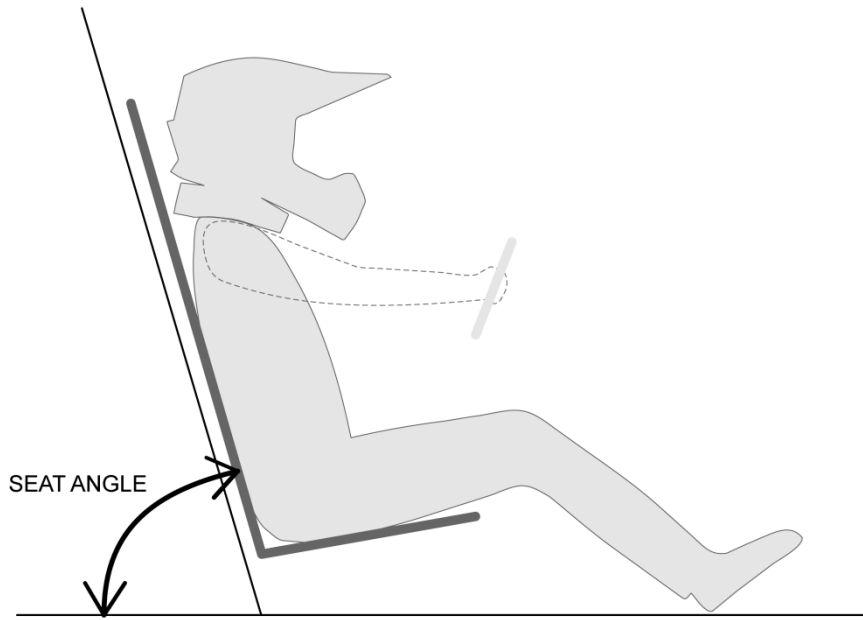

Figure B-41: Seat Angle

B.4.5.1 - Seat Construction

B.4.5.1.1 - Conventional Seats

Conventional seats shall be generally rigid and be of metal or composite construction (fiberglass or carbon fiber). Seats constructed of thermoplastic are prohibited. Conventional seats may also have a removable seat cover and/or closed-cell foam padding. The maximum thickness of the foam padding shall be 2.0 inches (50.8 mm). Seats may be purchased from a manufacturer or constructed by teams.

B.4.5.1.2 - Suspension Seats

Suspension seats, sling seats, hammock seats, or similar designs with webbing or cordage as the primary load path are explicitly prohibited.

B.4.5.2 - Seat Design

Seats shall be designed to have at least two generally planar surfaces when the driver is seated in the vehicle. The seat back plane shall be inclined between 65 and 90 deg from horizontal as viewed from the side (see Figure B-41: Seat Angle.) The vehicle's firewall shall not be considered as any part of the seat. The seat bottom plane shall be underneath the driver and be horizontal or generally sloped such that the leading edge of the seat bottom plane is level with or higher than the intersection with the back plane. Seats may also include material oriented vertically along the sides of the seat bottom plane and the seat back plane designed to assist in laterally restraining the driver.

B.4.5.3 - Seat Mounting Points

B.4.5.3.1 - Quantity

All seats shall have no less than six (6) total mounting points to the vehicle frame. Seats shall have no less than four (4) mounting points from the seat bottom plane and no less than two (2) mounting points

from the seat back plane. Seats shall be mounted with tabs meeting the requirements of B.12. The minimum fastener diameter for seat mounting points is ¼ inch.

B.4.5.3.2 - Arrangement

The seat bottom plane and seat back plane mounting points shall be generally symmetrical about the longitudinal center line of the seat itself or the vehicle. Seat back plane mounting points shall be at or near the plane of the RRH. All seat mounting points shall attach to the LFS, USM, RRH or other tubes having met the requirements of secondary roll cage members. Each seat bottom mount shall be designed to evenly distribute vertical load.

B.4.5.3.3 - Structure

Any tabs used to mount the seat shall meet the requirements of B.12.2 - Required Attachment Tabs. When mounting with tabs, direct contact of the tab to the seat is preferred, spacers up to 13mm (0.5in) will be allowed. Any tube used to mount the seat with radial holes drilled in the tube shall be sleeved and reinforced per rule B.3.6 - Drilled Members.

Article 5 - Driver Equipment

B.5.1 - Helmet

All drivers must wear a properly sized motocross-style helmet with an integrated (one-piece composite shell) chin/face guard.

All helmets used in Baja SAE® shall be meet the requirements of Snell M2020, or ECE R22-05, R22-06. Any helmets not meeting these standards are explicitly prohibited.

Note: Some Motocross helmets have extended chin guards that will not contact the required neck collars when the head is flexed forward. This combination of helmet/collar system is prohibited.

Note: Any non-specification helmets will be confiscated by the NTI for the duration of the event. At the close of the endurance race, all confiscated items will be available for pick up.

Caution: Do not rely on salespeople to determine if a helmet is Snell rated. Check for the Snell sticker under the foam liner of the helmet.

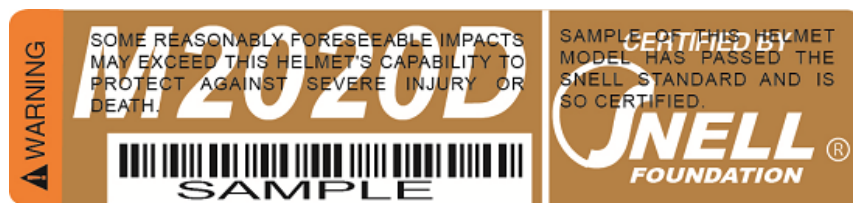

Figure B-42: Driver Equipment, Example Snell Sticker



Figure B-43 : Driver Equipment, Example ECE Tags

B.5.2 - Eye Protection

B.5.2.1 - Type

All drivers shall wear motocross-style goggles with a full-circumference elastic band that wraps completely around the driver's helmet. "Quick Straps" or other quick-release systems are explicitly prohibited.

B.5.2.2 - Lens Protection

All goggles used by drivers must have tear-off or roll off lens protectors. These tear-offs or roll-offs are used to ensure the driver has unobstructed vision through their goggles. Teams must present their goggles and properly installed tear offs or roll-offs at tech inspection. Teams without tear offs or properly functioning roll offs are subject to being black flagged.

B.5.3 - Neck Support

B.5.3.1 - Certification

All drivers must wear a neck support / neck collar. The neck support must be a full circumference (360 deg.) and SFI 3.3 rated. Horseshoe collars are not allowed. Simpson, RCI, GForce, Deist or Leaf Racing Products supply neck collars that meet this requirement.

The support/collar must be in overall good condition and show no signs of wear or other injurious defects. The support/collar must bear the appropriate SFI labels.



Figure B-44: Driver Equipment, Neck Support

B.5.3.2 - Expiration

Neck support expiration dates are not required.

B.5.4 - Clothing

B.5.4.1 - Gloves

Drivers shall wear gloves to protect their hands. Durable, abrasion resistant gloves are required.

B.5.4.2 - Shoes

Drivers shall wear socks and shoes.

B.5.4.3 - Upper Garments

Drivers shall wear a fire resistant shirt or suit rated SFI 3.2, SFI 3.3, SFI 3.4, or FIA 8856-2000 in good condition. The condition of the garment shall be made by the NTI. Any garment not allowed by the NTI will be confiscated for the duration of the competition and may be retrieved by the team at the end of the competition.

B.5.4.4 - Lower Garments

Drivers shall wear properly sized fire resistant long pants having an SFI, FIA, NFPA 2112, or other fire resistant rating.

B.5.4.5 - Combustible Material

Jerseys, gloves, socks or other garments made from nylon or any other synthetic material which will melt or combust when exposed to open flame or extreme heat, are explicitly prohibited from use during competition.

Article 6 - Fuel System

B.6.1 - Function

All vehicles shall have a fuel system comprising of a fuel tank, fuel hose and fittings, and splash shields. The fuel system shall function to safely contain and control fuel and to safely convey fuel to the engine carburetor. The entire engine is considered to be part of the fuel system.

B.6.2 - Fuel

The only fuels permitted for Baja SAE® competitions are grades of automotive gasoline consisting of hydrocarbon compounds. The fuel may contain anti-oxidants, metal deactivators or corrosion inhibitors.

B.6.2.1 - Specific Gravity

The specific gravity of the fuel may not exceed 0.80 for unleaded gasoline when measured at 15.5 deg. C (60 deg. F).

B.6.2.2 - Prohibited Additives

The addition of nitrogen bearing additives, or additives designed to liberate oxygen is explicitly prohibited. Leaded gasoline is explicitly prohibited.

Caution: Lead alkyl compounds such as tetra-ethyl lead are explicitly prohibited.

B.6.3 - Location

The entire fuel system, including fuel tank, fuel hoses, fuel mounts, carburetor, air cleaner cover, splash shield, and engine must be located within the roll envelope of the vehicle. Roll envelope is defined as tubing structure, fully welded to the vehicle Roll Cage, or meeting the requirements of B.3.5. The envelope shall be tested by means of a straight edge in contact with any two points on the outside of the vehicle frame. The fuel tank mountings must be designed to resist sustained vibration and shock.

Remote engine air intakes and remote engine air intake hoses are exempt from this rule and may be mounted outside of the roll envelope.

B.6.4 - Fuel Cap

The fuel cap included with the Pyrotec fuel tank, or a Briggs and Stratton fuel cap with built-in check valve (Part Number: B4325GS), is required. A protective cover may be attached to the fuel cap with adhesive to protect blockage of the vent hole.

B.6.5 - Fuel Tank

One fuel tank is permitted on the vehicle. Fuel tanks shall be unmodified and free from injurious defects. Application of stickers, paint, or other coatings shall be considered a modification. The only permitted fuel tank is Pyrotec Part Number SFC1000, available on the Pyrotec website (<http://pyrotecstore.com/shop>). The retail price of the fuel tank must be included in the cost report. Note: The fuel tank is anodized by Pyrotec.

B.6.5.1 - Mounting

Fuel tanks shall be mounted to a tube or tubes meeting the requirements of at least a secondary member. Tubes shall be supported at both ends. Cantilevered mounting is explicitly prohibited.

Removable fuel tanks are explicitly prohibited.

All mounting holes on the fuel tank shall be used to mount the fuel tank to the vehicle frame. Any and all fasteners used to mount the fuel tank shall meet the requirements in Article 12 – Fasteners. A rubber isolating washer, specifically McMaster Carr Part Number 94733A723, shall be used on each fastener, on both sides of the fuel tank mounting flange. A total of 8 rubber washers are required.

Metallic washers shall be used on either side of the fastener stack-up, as shown in Figure B-45: Fuel Tank Fastener Stack-up. Metallic washers and bolts shall have a nominal fastener size of 3/8 in. and washers to have an outside diameter between 0.812 in. and 0.875 in.

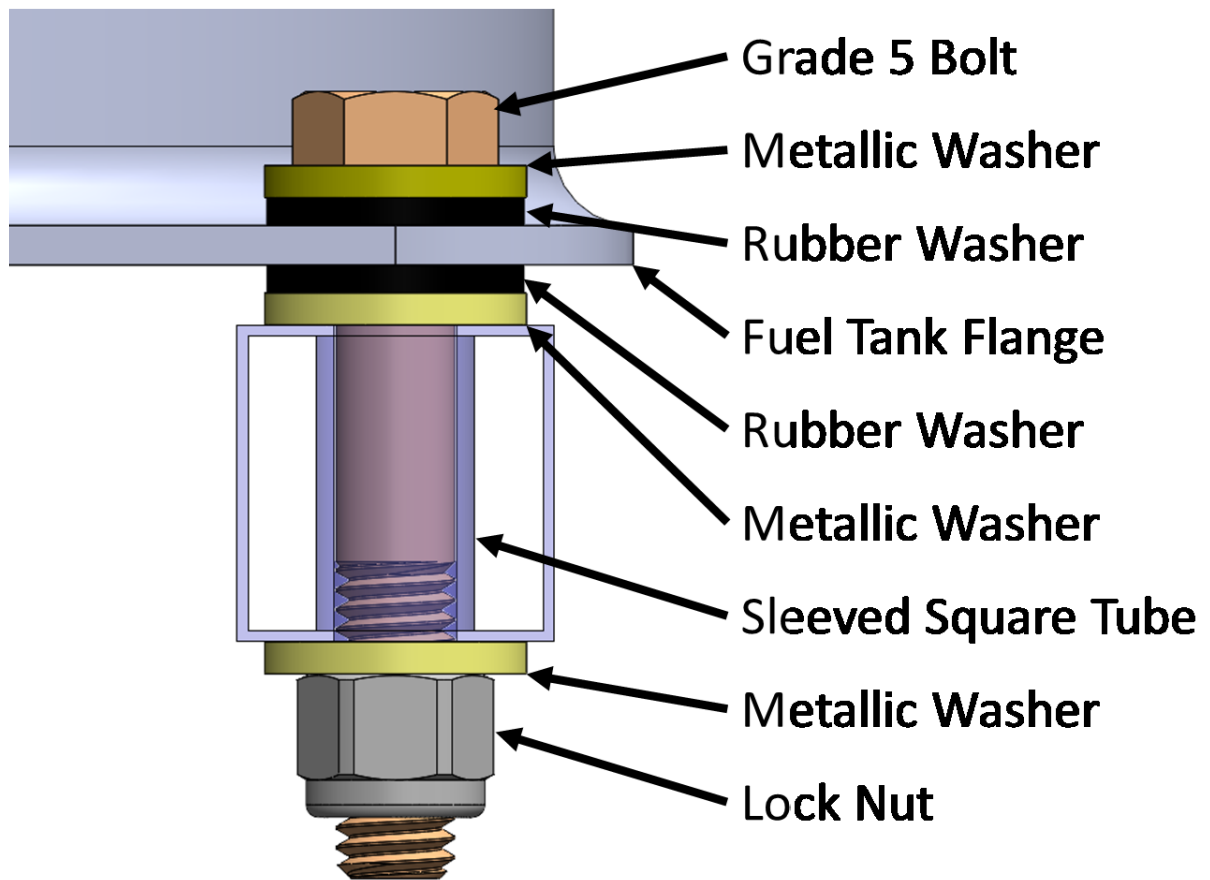

Figure B-45: Fuel Tank Fastener Stack-up

The preferred mounting is directly to two square or rectangular tubes with sleeved holes, and meeting the requirements of secondary members.

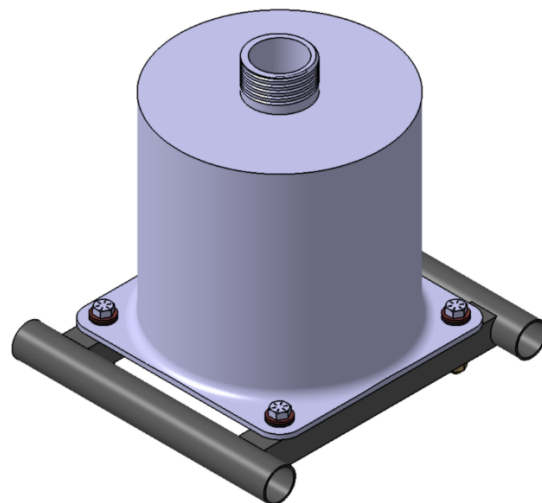

Figure B-46: Fuel tank mounted to square/rectangular tubes (preferred mounting design)

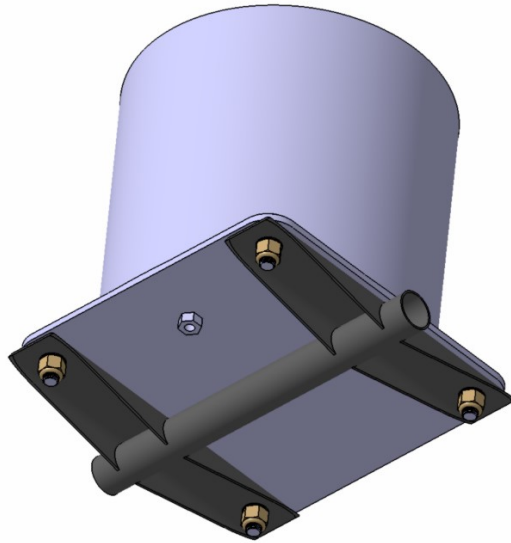

Figure B-47: Fuel tank mounted to "C" brackets. (Acceptable mounting design)

Mounting to cantilever brackets (welded to a fully supported secondary frame tube) as shown in Figure B-47 is acceptable within the following requirements.

- 1) Maximum Length: Bracket length may not exceed 101.6 mm (4 in.) from weld-line to center of mounting hole.
- 2) Minimum edge distance: 14.3 mm (0.5626 in.), measured from the edge of the bolt hole to the nearest outside edge of tab, and 12.7 mm (0.375 in) from the edge of the bolt hole to the nearest bend tangency. If using square tubing to form the brackets, a minimum 31.75 x 1.6mm (1.25 x 0.0623 in) tubing shall be used.
- 3) Allowable cross section: Brackets shall have a "C" cross-section. The supporting gussets may be tapered as shown in Figure B-48, and shall be a minimum 22.9 mm (0.9 in) tall at the weld. Flat brackets are not permitted.

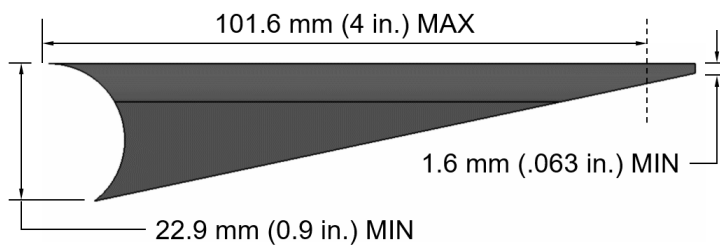

Figure B-48: Allowable Taper

- 4) Minimum Thickness: 1.6 mm (0.063 in.)

- 5) Minimum Weld Length: At least the full outside face of the bracket must be welded to the supporting tube as shown in Figure B-49.

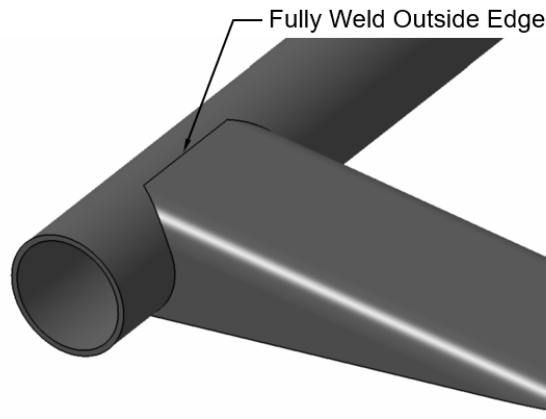

Figure B-49: Minimum weld length

- 6) Lightening holes or cutouts other than the bolt hole are explicitly prohibited.

B.6.6 - Fuel Lines and Filters

B.6.6.1 - Location

All fuel lines shall be located away from sharp edges, hot engine components and be protected from hot engine components, chafing, or abrasion. Grommeting is required where the lines pass through any member of the vehicle. Fuel lines are prohibited in the cockpit.

Fuel lines shall have sufficient slack to not be held in tension. Fuel lines shall be secured to fittings with SAE Size #4 adjustable metal clamps or Kohler OEM clamps.

Any breaks (discontinuities) in the fuel line, including those for fuel fittings such as filters, sensors, or cut-out valves shall be located above the spill pan.

The fuel line shall be continuous between the last connection above the spill pan and the carburetor. The fuel line should pass around the spill pan or if the fuel line passes through the splash shield the fuel line shall be able to freely move up and down. Any attachment points below the spill pan not directly mounted to the engine shall allow the fuel line to freely move up and down.

Note: To provide strain relief for the fuel line, it is recommended to attach a snug fit clamp to the engine that matches the OD of the fuel line. Example McMaster-Carr part #3177T52.

B.6.6.2 - Rating

All fuel lines shall be SAE J30 rated fuel lines and bear appropriate OEM labels with rating information.

B.6.6.3 - Size

All fuel lines shall be "3/16 inch" (trade size).

B.6.6.4 - Fuel Filters

A Kohler in-line fuel filter is required and shall be located above the splash shield. No more than one (1) fuel filter may be used at a time.

B.6.6.5 - Fuel Sensors

Fuel level gauges and sensors are allowed as long as the fuel tank is not modified. Fuel level gauges and sensors are allowed such that the capacity of the fuel system is not increased.

B.6.6.6 - Fuel Pumps

Fuel pumps are prohibited.

B.6.7 - Splash Shields

Splash shields are required to prevent fuel from accidentally being poured directly on the engine or exhaust while refueling or preparing to refuel the vehicle. Splash shields shall divert spilled fuel away from the axis of the exhaust gases. For example, if the exhaust is routed directly aft of the vehicle, the splash shield shall divert spilled fuel to the left or right side of the vehicle.

The splash shield shall be constructed of metallic material (greater than 0.5 mm or 0.02 inches thick). Shields must be generally rigid, shaped such that any spilled fuel runs towards the outside of the vehicle, away from the exhaust, and does not pool on the shield or anywhere on the vehicle (including skid plates). An example arrangement of splash shielding is shown in two views in Figure B-50.

Splash shields shall be mounted so they are engaged and effective at all times and are not adjustable. The splash shield must be mounted lower than the structural member supporting the fuel tank. The splash shield shall have a minimum clearance of 13 mm (0.5 in) to the exhaust and shall not be impinged upon by exhaust gases.

If the fuel line passes through the splash shield, it must pass through a sealed, grommeted hole in the shield to prevent fuel from leaking on the engine. Bulkhead fittings are not permitted.

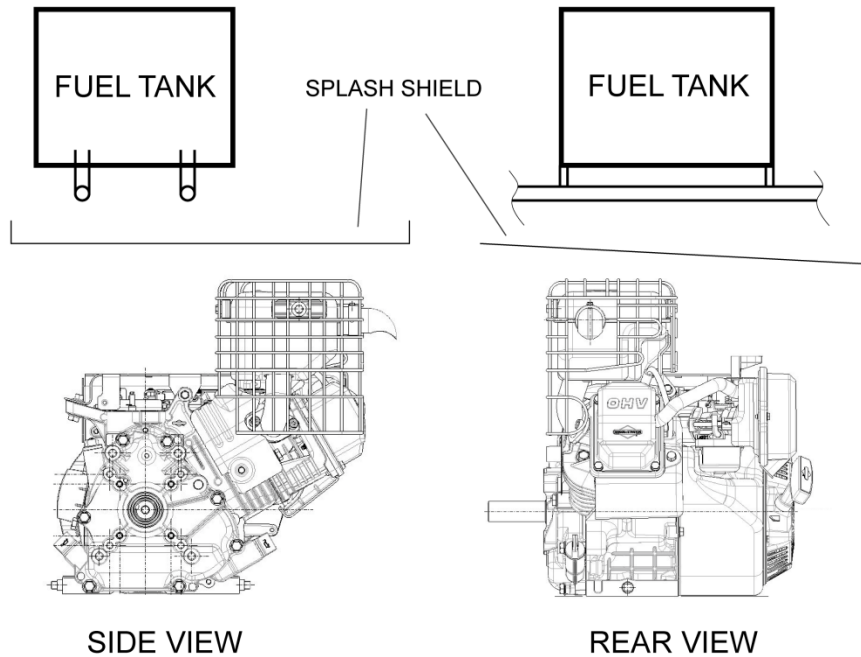

Figure B-50: Fuel System, Splash Guard Installation Example

B.6.8 - Fuel Containers

All fuel must be transported in, and put into vehicle fuel tanks, from approved, unmodified containers. Approved, unmodified containers shall:

- Have a volume of 5.7 L (1.5 gal.) or less for fueling vehicles during endurance event.
- Have a volume of 18.9 L (5 gal.) or less for all other capabilities.
- Be equipped with an original cap to prevent spills when not in use.
- Be labeled with school name and car number.

Teams are required to bring all fuel to the fueling zone during the endurance event, see rule D.8.3.7 - Refueling.

B.6.9 - Fuel Tank Access Panels

To provide line-of-sight for track safety workers, an observer directly behind the vehicle shall have an unobstructed view of the fuel tank and associated components.

Article 7 - Vehicle Controls

B.7.1 - Brake System

The vehicle must have a primary hydraulically actuated friction braking system that acts on all wheels and operated by a single foot pedal. The pedal must directly actuate the master cylinder through a rigid link (i.e., cables are not allowed). The brake system must be capable of locking and sliding all wheels, both in a static condition as well as at-speed, regardless of surface conditions or drivetrain mode. The braking system shall have sufficient force to hold the vehicle while the engine is running in any powertrain configuration used at competition. Brake pedals and associated components shall be constructed from steel or aluminum, and be designed to withstand a minimum brake pedal force of 450 lbf (2000 N).

The performance of the braking system shall be subject to test upon request of NTI at any point during competition. Failure of this performance test will result in teams being required to return to their paddocks to make sufficient repairs before participating in further competition.

B.7.1.1 - Independent Circuits

The braking system must be segregated into at least two (2) independent hydraulic circuits such that in case of a leak or failure at any point in one system, effective braking power shall be maintained on at least two wheels. Teams are encouraged to construct each circuit to have its own physically separate fluid reservoir. A dammed, single-reservoir serving two circuits is currently permitted.

B.7.1.2 - Brake Location

The brake(s) on the driven axle must operate through the final drive. Inboard braking through universal joints is permitted. Braking on a jackshaft through an intermediate reduction stage is prohibited.

B.7.1.3 - Cutting Brakes

Hand or feet operated “cutting brakes” are permitted provided the section B.7.1 is also satisfied. A primary brake system must be able to lock all four wheels with a single foot. If using two separate pedals to lock two (2) wheels apiece; the pedals must be close enough to use one foot to lock all four wheels.

Any and all brakes, when actuated, shall cause the brake light to illuminate.

B.7.1.4 - Brake Lines

All brake lines shall be securely mounted to the vehicle and not project below the vehicle frame or suspension components.

All brake lines shall be routed and oriented such that they are not pinched by steering or suspension parts, nor engaged with sharp edges.

All brake lines shall have full range of motion within the steering and suspension system.

At no time shall the brake lines be loaded in tension or become engaged with the vehicle's tires and wheels.

All brake lines shall be designed for the pressures expected in the braking system, and be chemically compatible with the brake fluid in use.

No brake line may be constructed of plain, plastic tubing.

B.7.2 - Throttle System

The vehicle's throttle system shall be capable of fully actuating the throttle arm to full throttle (100%) on the engine and return to idle (0% throttle) when released. The throttle shall remain in the as-inspected condition for the duration of the event. Re-inspection is available by appointment with Kohler at the event site. “Throttle-by-wire” or other electronic throttle controls are explicitly prohibited.

B.7.2.1 - Pedal

Only mechanical, pedal (foot) operated throttle controls are allowed. The throttle pedal shall actuate a throttle cable.

Foot pedals shall be positioned to avoid entrapment of the driver's foot when in any position.

Mechanical extensions such as thick pads or blocks may not be attached to the pedal or to the driver's feet.

B.7.2.2 - Pedal Stop

A substantial, mechanical, wide-open throttle stop must be mounted at the pedal. Body panels or other flexible materials are explicitly prohibited. The pedal stop shall be accessible during engine check and will be set to not over-extend the Kohler engine throttle linkage system.

B.7.2.3 - Throttle Cable

The throttle cable must be covered (sheathed or jacketed) from the forward mounting point in the cockpit and the vehicle firewall.

Kohler recommends Kohler designed throttle connections. See BajaSAE.net for more information. If manufacturing your own throttle connection system to the engine, the connector to the throttle linkage arm must be pulled between plus 5 and minus 5 degrees from the linkage arm as not to impact the high speed setting of the engine.

Throttle cables may be of "bicycle style" construction where the cable operates only in tension (pull only).

Throttle cables may be of "aircraft style" construction where the cable is capable of tension and compression (push-pull) operation.

Severe redirections of the throttle cable at the engine or the throttle pedal causing binding or restricted function are prohibited. Redirections more than 15 degrees from the cable jacket centerline are not recommended.

B.7.2.4 - Fail Safe

All throttle controls shall be designed to return to the idle-stop in the event of a failure. The throttle cable must be covered (sheathed) between its forward mounting point and the firewall to prevent debris ingress.

B.7.3 - Other Control Systems

B.7.3.1 - Compressed Gas Systems

Compressed gas systems are only permitted for vehicle control systems. For example, a compressed gas system may be used to change transmission states (i.e. shift gears). Compressed gas systems are explicitly prohibited from providing increased engine power, cooling, and/or vehicle propulsion. The NTI reserves the right to require additional protections or safety features on any compressed gas system.

B.7.3.1.1 - Gas Composition

Compressed gas systems shall operate only with non-flammable or non-oxidizing gases. Air, nitrogen, and carbon dioxide are examples of acceptable gases. Methane, propane, and oxygen are examples of unacceptable gases.

B.7.3.1.2 - Gas Storage

Compressed gases shall be stored in containers meeting the following requirements.

- a. Compressed gases shall be stored in cylinders (tanks) of propriety manufacture, designed and built for storage and operating pressures, certified by an accredited testing laboratory in the country of the cylinder's origin, and be labeled or stamped appropriately.

- b. The compressed gas cylinder shall be located within the roll envelope and aft of the RRH, protected from rollover and collision damage.
- c. The compressed gas cylinder shall be protected from damage from failed rotating equipment.
- d. The compressed gas cylinder shall be securely mounted to the vehicle frame, engine, or transmission, and oriented such that the longitudinal axis of the cylinder is not in line with the driver.
- e. The compressed gas cylinder shall be insulated from excess heat such as the engine or exhaust.

B.7.3.1.3 - Gas Service Equipment

All service equipment in the compressed gas system shall meet the following requirements.

- a. Pressure Regulators shall be rated for compressed gas service and be mounted directly to the compressed gas cylinder.
- b. Any and all fittings or connectors in the compressed gas system shall be rated for the pressures and temperatures experienced downstream of the pressure regulator.
- c. Any and all hoses, tubing, or other conveyances in the compressed gas system shall be rated for the pressures and temperatures experienced downstream of the regulator.
- d. Any and all gauges, indicators, or other instrumentation in the compressed gas system shall be rated for the pressures and temperatures experienced downstream of the regulator.

B.7.3.1.4 - Compressed Gas Mechanisms

All compressed gas mechanisms, including cylinders, slides, actuators, or motors shall be rated for the pressures and temperatures experienced downstream of the regulator.

Article 8 - Cockpit

B.8.1 - Design Objective

The cockpit shall be designed to protect the driver and permit easy egress in an emergency.

B.8.2 - Cockpit Egress

Any and all drivers must be able to egress (exit) on either side of the vehicle within five (5) seconds. Drivers tested for egress time shall begin with all safety gear and be fully seated and secured in the vehicle with their hands on the connected steering wheel.

Egress time is timed from the instant either hand of the driver is removed from the steering wheel to the instant the driver is clear of the vehicle.

The NTI will select one or more drivers to perform the cockpit egress test. Drivers unable to demonstrate successful egress will have their driver status revoked. Each team is required to have a minimum of two designated drivers.

B.8.3 - Firewall

All vehicles shall have a firewall separating the cockpit from the engine and fuel tank compartments. The firewall shall be constructed of metal, at least 0.50 mm (0.02 in.) thick. The firewall shall be mounted in the plane of the RRH and cover the area between the ALC and BLC.

Multiple metal panels may be used to form the firewall, provided there are no gaps between the joints. Select cutouts are allowed for control cables, brake lines, or electrical cables, provided the cutouts have proper grommeting and sealing.

Large cutouts in the firewall are explicitly prohibited. Large cutouts include those for CVT ventilation, and other similar items. Air intakes may not penetrate the firewall and must remain within the roll envelope. Cutouts for drivetrain components are permitted.

B.8.4 - Front or Mid-Engine Vehicles

If the mounting points of the engine are completely forward of the RRH, then a firewall is not required to cover the area between within the plane of the RRH and between the LC's of the RRH. If the mounting points of the engine are completely forward of the RRH, the following requirements must be met:

- a. The fuel tank shall be enclosed in a sealed container that prevents fuel from leaking in the event of a fuel tank failure.
- b. Splash shields must prevent fuel from being poured anywhere in the cockpit area during fueling.
- c. The engine shall be completely enclosed and the enclosure shall protect the driver in the event of an engine failure. The engine enclosure shall be metal and meet the requirements of Article 9 - Powertrain Guards.
- d. Engine enclosures must prevent fuel from spilling into the cockpit should the vehicle be involved in a collision or roll-over.
- e. All engine compartment venting shall be directed away from the cockpit.
- f. The driver must be able to egress from both sides of the vehicle.
- g. The engine exhaust shall not exit in the direction of the driver and shall be shielded from contact by track workers and competition officials.
- h. A panel, 300 mm x 300 mm (12 in. x 12 in.), shall be affixed to the vehicle in the plane of the RRH, on the right side of the driver's head, and above the shoulder level of the tallest driver. This panel shall be used to affix the Technical Inspection sticker, and shall be easily viewed by track workers and competition officials.

B.8.5 - Body Panels

The cockpit must be protected with body panels that completely cover the area between the LFS and the SIM. No gaps can exist that are larger than 6.35 mm (0.25 in) and will be checked with a 6.35 mm (0.25 in dowel rod). These panels must be made of puncture resistant material, including: plastic, fiberglass, metal, or similar material. They must be designed to prevent debris and foreign object intrusion into the driver compartment. The panels must be mounted securely to the frame using sound engineering practices (cable ties or hook-and-loop fastening is not acceptable).

Note: Quick disconnect or easily accessible fasteners for body panels are recommended, and facilitate a faster technical inspection process.

B.8.6 - Skid Plate

The cockpit must be fitted with a skid plate (belly pan) over the entire length of the cockpit, so that the driver cannot contact the ground and is protected from debris while seated normally. Skid plate material shall be metal, fiberglass, plastic, or similar material. Skid plates shall be designed to prevent debris and foreign object intrusion into the driver compartment. Expanded metal, fabric, or perforated panels are not allowed. Skid plates extending aft of the firewall shall have features to prevent leaking fuel from entering the cockpit.

B.8.7 - Shielding for Legs and Feet

B.8.7.1 - Linkages

All steering or suspension links exposed in the cockpit shall be shielded with a sturdy, robust, metal cover. The shielding shall be continuous and extend the full width of the cockpit (from the left body panel to the right body panel) and shall prevent the driver's legs and feet from coming in contact, becoming entangled, or struck by the steering or suspension components during operation or a failure. No gaps may exist that are larger than 6.35 mm (0.25 in).

Note: Quick disconnect or easily accessible fasteners for cockpit steering & suspension covers are recommended, and facilitate a faster technical inspection process.

B.8.7.2 - Universal Joints

Universal joints in the steering system or 4WD/AWD system and near the driver's feet shall be shielded or sealed such that the driver may not become entangled in the joint.

Caution: Loose shoelaces can and have become entangled in universal joints and steering parts and will hinder driver egress from the cockpit.

B.8.8 - Fire Extinguisher

All vehicles shall be equipped with a charged and functional fire extinguisher in the event of a fire on the vehicle, in the paddocks, or on the track. All team members shall be familiar with the use and operation of fire extinguishers.

B.8.8.1 - Rating and Required Features

All fire extinguishers for use on the vehicle shall have a minimum UL rating of 5BC. All fire extinguishers for use on the vehicle shall be equipped with a manufacturer installed dial pressure gauge. The dial pressure gauge shall be readily visible and indicate the unit has been properly charged. Each fire extinguisher shall be labeled with school name and vehicle number. Each fire extinguisher shall be equipped with an OEM-type pull pin and OEM-type retainer installed.

B.8.8.2 - Quantity

Each team shall have two or more fire extinguishers meeting the requirements above. One fire extinguisher shall be installed on the vehicle, and the remaining extinguishers shall serve as spares.

B.8.8.3 - Required Bracket

The only permitted fire extinguisher mounting brackets are the:

- DV8 Off Road D-FIREX-MNT-DOR
- DV8 Off Road D-FIREX-MNT-S-DOR
- Drake FIREX-MNT-DAG
- Drake FIREX-MNT-S-DAG

Note: It is recommended teams keep a spare mount available.

B.8.8.4 - Mounting

The fire extinguisher mounting bracket shall be mounted in the plane of the vehicle's RRH. The fire extinguisher mounting bracket shall be affixed to the RRH via steel tabs meeting the requirements of B.12.2 - Required Attachment Tabs or B.6.5.1 - Fuel Tank Mounting.

Mounting hardware shall be flat socket head cap screws with a countersink angle and head diameter matching the required Drake bracket. Hardware used to secure the bracket to the vehicle frame shall meet all requirements of Article 12, Fasteners.

The fire extinguisher shall be affixed to the mount via hose clamps such that the nozzle is pointed into the firewall or laterally away from the driver. The hose clamp adjusters shall be installed as not to interfere with the operation of the pull-knob on the Drake bracket. The hose clamp adjusters and protruding material shall be installed as not to snag on the clothing of a driver during vehicle egress. Hose clamps shall not be oriented in the manner described by Figure B-51. An example of incorrect clamp routing is shown in Figure B-52.



Figure B-51: Incorrect orientation of extinguisher clamps.



Figure B-52: Incorrect routing of hose clamps.

B.8.8.5 - Location and Clearance

The fire extinguisher shall be positioned on the right side of the driver, within the cockpit such that the fire extinguisher is completely below the driver's eye-level, and the top half of the fire extinguisher is above the SIM. The fire extinguisher shall be easily accessible by track workers.

The pull knob of the required bracket shall be easily actuated. To facilitate this, a minimum radial clearance around the pull knob of 64 mm (2.5 in.) is required. It is understood the area aft of the pull knob will be less than 64 mm (2.5 in.) due to the design of the bracket. See figure for further clarification.

Note: Radial clearance is the unoccupied space between the edge of the pull knob and the nearest obstruction. The measurement is not made to the center of the pull knob.

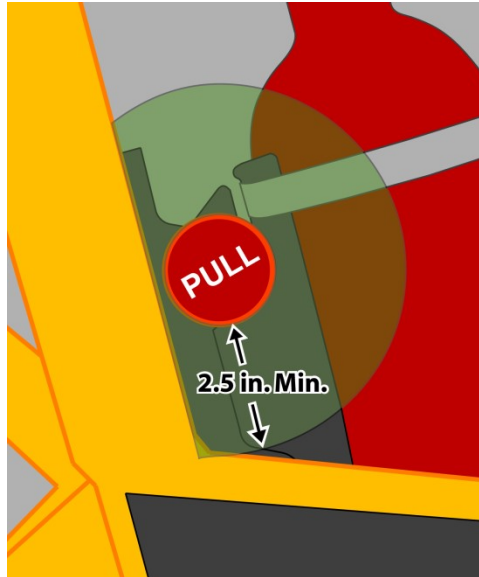

Figure B-53: Fire Extinguisher, Diagram of Clearance around Pull Knob (green)

Article 9 - Powertrain Guards

B.9.1 - Powertrain Guard Function

All powertrain components shall be guarded and shielded to prevent injury to the driver, track workers, or bystanders.

Powertrain guards shall perform one or more of the following functions: protect against hazardous release of energy, provide pinch point and entanglement protection, or protect against release of lubricating oil from gearboxes.

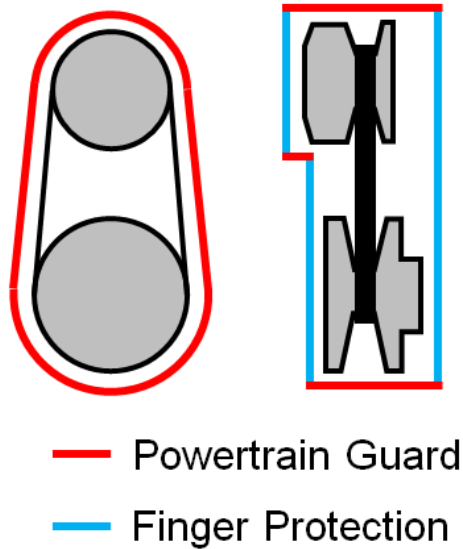

Figure B-54: Powertrain Guard Extent example on a CVT

B.9.2 - Hazardous Release of Energy (HROE)

Powertrain guards shall safely dissipate a sudden, hazardous release of energy from powertrain components in the radial and tangential directions. HROE guards shall be durable and mounted with sound engineering practices. HROE guards shall extend around the entire periphery of the guarded components.

B.9.2.1 - HROE Guard Materials

All HROE guards shall be constructed of one or both of the following required materials:

- Steel, at least 1.5 mm (0.06 in.) thick, meeting or exceeding the strength of AISI 1010 steel.
- Aluminum, at least 3.0 mm (0.12 in.) thick, meeting or exceeding the strength of 6061-T6 aluminum.

B.9.2.2 - HROE Guard Features

B.9.2.2.1 - Belt, Gear, and Chain Drives

HROE guards shall be a continuous metal band extending around the entire periphery of the drive assembly. The width of the continuous metal band shall be wider than the entire width of the rotating component by a minimum of 13 mm (0.5 in) on each side. Multi-part covers must have at least 0.5 inch (12 mm) of overlap at joints along the periphery.

HROE guards may contain ventilation ports along the path of the guard. Ventilation ports shall be constructed from the same material as the guard, be arranged in such a manner that no radial or tangential path exists for flying debris to exit the ventilation port. The ventilation port shall also be constructed to not allow a searching finger to contact the rotating components when the ventilation tube is removed.

B.9.2.2.2 - Driveshafts

Driveshafts, also known as prop shafts, rotate at speeds faster than the drive axles and typically distribute power to front and rear differentials.

All drive shafts shall be constrained from failure via two drive shaft hoops, within 51 mm (2.0 in.) of the 1/3 length point and the 2/3 length point. Hoops should have no more than 25.4 mm (1.0 in) clearance to the driveshaft. The driveshaft hoops shall be a minimum of 25.4 mm (1.0 in.) wide and shall be mounted by welding or threaded fasteners. Hoop mounting must rigidly connect the hoop to the frame via material meeting or exceeding HROE requirements.

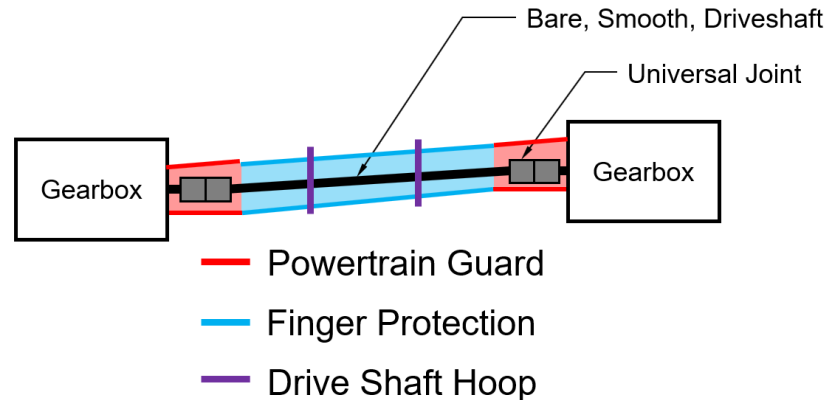

Figure B-55: Driveshaft Guarding

B.9.2.2.3 - Hydraulic Systems

Hydraulic systems shall protect against hazardous release of energy. Hydraulic hoses shall have jacketing that meets HYDRAULIC SPEC. Hydraulic relief valves shall safely vent to the tank and away from people.

Any hydraulic hoses running through the cockpit to the front axle shall be protected from damage by a driver entering or exiting the vehicle. Protection shall be made by a sturdy, robust cover. Note that hydraulic systems shall meet the requirements of B.2.6.1 - Hydraulic.

B.9.2.2.4 - Axleshafts

Axle shafts and associated CV or universal joints forward of the firewall directly connecting the front wheels/uprights to the front differential do not require specific guarding for track workers and bystanders, but shall be separated from the driver and cockpit by way of methods meeting requirements of B.8.5 - Panels and B.8.6 - Skid Plate.

All other universal joints, CV joints, or similar shall be protected with HROE guarding extending 25.4 mm (1.0 in.) axially beyond the extent of the joint.

B.9.3 - Pinch Points and Entanglement (PPAE)

Pinch point and entanglement guarding shall prevent clothing and/or searching fingers from contacting or becoming injured in rotating parts. PPAE guarding shall be resilient and be mounted with sound engineering practices.

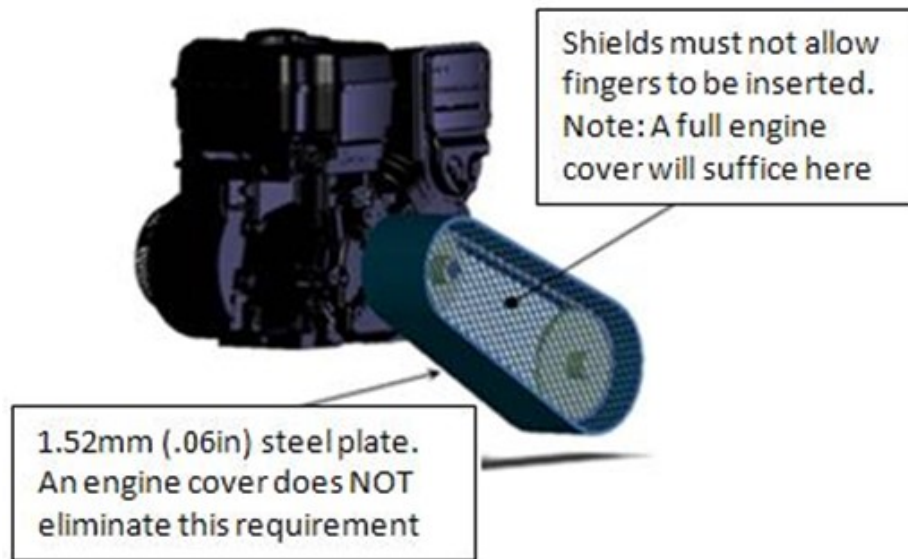

Figure B-56: Powertrain Guard Example

B.9.3.1 - PPAE Guard Materials

PPAE guarding shall be constructed from rigid, resilient materials. Fabric or other similar materials are explicitly prohibited.

B.9.3.2 - PPAE Guard Features

PPAE guarding for belt, gear, and chain drives shall cover all directions that HROE guard does not protect. PPAE guarding may contain holes or slots for ventilation.

Fastening methods may consist of threaded fasteners or quick release latches. Temporary fastening methods such as hook-and-loop fasteners, adhesives, or ratcheting tie-downs are explicitly prohibited.

B.9.3.2.1 - Belt, Gear, and Chain Drives

Belt, gear, and chain drives shall have PPAE guarding

B.9.3.2.2 - Driveshafts

All driveshafts shall have PPAE guarding. Drive shafts (prop shafts) connecting to rigid (solid) axles are exempt from PPAE requirements.

B.9.3.2.3 - Axleshafts

Axle shafts and associated CV or universal joints aft of the firewall directly connecting the rear wheels/uprights to the rear differential are exempt from the requirements of this article. Portal hubs/uprights are permitted.

Axle shafts and associated CV or universal joints forward of the firewall directly connecting the front wheels/uprights to the front differential do not require specific guarding for track workers and bystanders, but shall be meet the requirements of B.8.5 - B.8.6 - Body Panels.

B.9.4 - Drivetrain Breather / Vent System

Gearboxes and transmissions using lubricants such as gear oil, automatic transmission fluid, or similar mineral oils shall be equipped with a vent system that shall minimize loss of fluid by way of a rollover and by thermal expansion. This shall be accomplished either with a closed system expansion chamber or an air trap vent system. Portal hubs are exempt from the requirements of this rule.

If a closed system with an expansion chamber is used, the expansion chamber shall be properly sized to match the fluid volume and temperature changes of the system being vented. If an air trap vent system is used it should create a sufficiently large air trap, and shall meet the following requirements:

Left-to-right or right-to-left hose routing must extend past the sides of the device being vented. There is no requirement for longitudinal horizontal routing.

Vertical hose routing must extend higher than the top of the device being vented and shall terminate below the device being vented.

Horizontal hose routing must be sloped for fluid lines to drain.

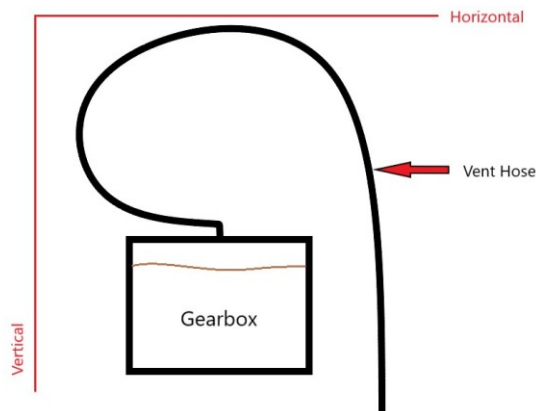

Figure B-57: Air Trap Vent Line Routing (Horizontal = Left to Right)

Differentials are classified as a gearbox and shall be vented by the same means unless the gearbox in question is separated from the engine by way of the firewall.

Expansion chambers and connecting hoses or tubes shall be constructed from a material suitable for transporting oil used in the gearbox or transmission. At all times, the vent line shall maintain a clearance of at least 100 mm (3.94 in.) from the exhaust.

All components of the vent system shall be within the rollcage of the vehicle. This will be checked the same way as the fuel system.

For remote mounted expansion chambers, the chamber may not be mounted above the engine.

B.9.5 - OEM Guards, Unmodified

Unmodified OEM guards are acceptable for meeting the guarding requirements in this article. Any OEM, factory stock guards that are not modified are exempt from the requirements in rule B.9.1 - Powertrain Guard. All powertrain components shall **be guarded and shielded to prevent injury to the driver, track workers, or bystanders.**

Powertrain guards shall perform one or more of the following functions: protect against hazardous release of energy, provide pinch point and entanglement protection, or protect against release of lubricating oil from gearboxes.

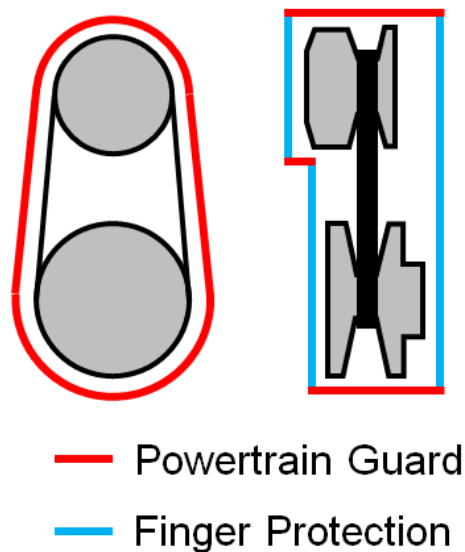

Figure B-54: Powertrain Guard Extent example on a CVT

Hazardous Release of Energy. OEM covers must still meet the requirements of B.9.3 - Pinch Points and Entanglement.

Article 10 - Electrical System

A minimum electrical system comprising of at least two engine kill switches, a brake light, brake switch, battery, and associated wiring is required. The vehicle electrical system shall be designed and constructed in accordance with good engineering and electrical practices. Brake lights, reverse lights and alarms shall operate regardless of kill switch setting. Brake lights, reverse lights and alarms shall be powered and functional at all times. Cut-out switches capable of interrupting power to the brake light, reverse light, or reverse alarm circuits are strictly prohibited.

B.10.1 - Power Sources

B.10.1.1 - Batteries

B.10.1.1.1 - Mounting

All batteries shall be mounted with sound engineering practices and not come loose during normal operation, a collision or rollover. Battery terminals shall be insulated and protected against an electrical short.

B.10.1.1.2 - Sealing

All batteries must be factory sealed and maintenance free. Batteries shall be incapable of being opened or serviced and not leak in the event of a collision or rollover.

B.10.1.1.3 - Capacity

Any battery used for safety appliances, (brake light, reverse light, reverse alarm), shall have sufficient electrical capacity to last the entire length of the endurance. If items other than safety devices are on the same battery (brake light, reverse light and alarm), then battery capacity and sizing case shall be able to be verified through available engineering calculations and supporting documents.

B.10.1.2 - Engine Alternator

If an alternator is used, only approved engine alternators may be selected. See rule B.2.7.16 - Alternator for further information.

B.10.1.3 - Solar Panels

Solar panels are permitted to recharge on-board batteries.

B.10.2 - Wiring and Connectors

All vehicle wiring and connectors shall be cleanly and neatly installed. Wiring shall be routed away from sources of excessive heat, abrasion, chafing, and possible short circuit. Wiring shall be installed and routed such that it does not become a hazard to cockpit egress.

B.10.3 - Engine Kill Switches

Engine kill switches shall be employed to ground the ignition circuit and shut down the engine. Cut-out or disabling switches or devices preventing the immediate function of the engine kill switches are strictly prohibited.

B.10.3.1 - Quantity

Each vehicle shall be equipped with a minimum of two (2) engine kill switches.

B.10.3.2 - Required Switch

The vehicle shall be equipped with one or more of the following required switches:

- Polaris Part 4015321 or 4019114
- Ski-Doo Part 01-171 (<http://www.mfgsupply.com/01-171.html>)
- WPS 27-0152 (<http://www.parkeryamaha.com/skidoostopswitch.aspx>)
- WPS 27-0154(<http://www.parkeryamaha.com/skidoostopswitch.aspx>)

The switches listed above shall only be used as engine kill switches.

Note: Older versions of the approved switches are allowed.

B.10.3.3 - Location

B.10.3.3.1 - Cockpit Switch

A minimum of one cockpit kill switch is required as defined by this rule. Additional cockpit kill switches are permitted provided the switch meets rule B.10.3.2 - Required Switch.

The cockpit kill switch shall be mounted on the left side of the driver, along the SIM, within reach of a driver that is properly secured in the vehicle. No other push button switches may be mounted along the Left SIM. Restraining the driver in any way to prevent accidental contact is explicitly prohibited.

B.10.3.3.2 - External Switch

One of the required kill switches shall be located within easy access to track workers on the right side of the vehicle, aft of the plane of the RRH, and forward of the right FAB_{UP}. The external kill switch shall be generally perpendicular to the firewall (± 15 deg), the axis of the switch action generally horizontal (± 15 deg), below named point B_R, and no further than 180 mm (7.0 inches), dimension "Z" in Figure B-58 , below named point B_R, and shall be mounted on a tab connected directly to the RRH. The external kill switch shall not be recessed more than 51 mm (2.0 inches) from the outside edge of the RRH tube.

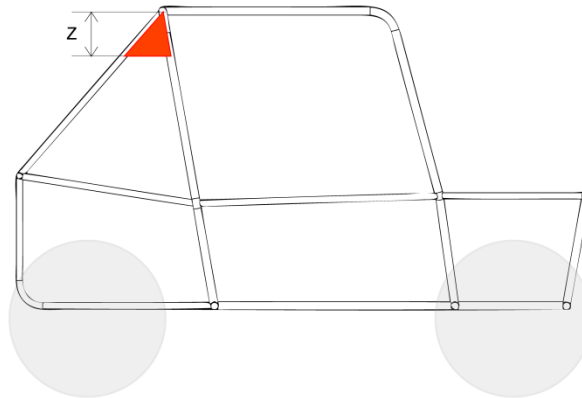

Figure B-58: Engine Kill Switch Mounting Position

B.10.3.4 - Mounting

All engine kill switches shall be rigidly mounted to the vehicle frame with unobstructed access to the switch. All engine kill switches shall be free and clear of sharp edges or other hazardous conditions to track workers or the driver. All switches shall be mechanically fastened to the frame. Adhesives are explicitly prohibited. If any threaded fasteners are used to mount an engine kill switch, they shall meet the requirements of Article 12 - Fasteners. Any type of guard, cover, or obstruction to prevent accidental contact is explicitly prohibited within 3" of the kill switch.

Note: Rivets and other robust, captive methods are acceptable fasteners for fastening kill switches to the mounting tab. Technical inspectors will evaluate each of these designs individually.

B.10.4 - Signaling

Each vehicle shall be equipped with signaling devices. Cut-out or disabling switches or devices preventing the immediate function of the required signaling devices are strictly prohibited.

B.10.4.1 - Brake Light

All vehicles are required to have a functional brake light to signal to other drivers the vehicle is stopping or slowing down.

B.10.4.1.1 - Required Brake Light

Only the following brake lights are permitted. Brake lights not listed are explicitly prohibited. Modification of the brake light from the OEM design is explicitly prohibited. All brake lights shall be configured to be fully illuminated when the brakes are applied, and completely extinguished with the brakes are released.

- Polaris Part # 2411450
- Polaris Part # 2411099

- Polaris Part # 2411092-432
- Haul-Master – Part # 93263
- Command Electronics Part # 003-6018R
- Command Electronics Part # 003-6016

B.10.4.1.2 - Location and Orientation

The vehicle brake light shall have a resilient and durable mount and be positioned at a minimum of 1000 mm (39.4 in.) above the ground. The vehicle brake light shall be oriented to be visible to trailing vehicles and shine parallel to the ground or at a slightly downward angle. Brake lights angled (aimed) above a horizontal plane are not permitted. The brake light must be visible at least at a 45 degree angle from the left and right of center, for a total field of view of at least 90 degrees.

B.10.4.1.3 - Brake Light Switch

The brake light shall be activated only by a hydraulic pressure switch installed in the brake hydraulic lines. Each independent hydraulic brake circuit must be equipped with a hydraulic pressure switch. Cutting brakes are required to activate the brake light by way of a hydraulic pressure switch.

Note: Mechanical switches, push or pull, are explicitly prohibited.

B.10.4.2 - Reverse Light

Vehicles with a reverse gear shall be equipped with a reverse light. The reverse light shall illuminate when the vehicle is shifted to reverse gear and is extinguished when the vehicle is shifted out of reverse gear.

B.10.4.2.1 - Specification

Reverse lights shall be marked with an SAE “R” on the lens of the reverse light and be of LED design, equal to or exceeding the SAE standard J759.

B.10.4.2.2 - Location and Orientation

The reverse light shall have a resilient and durable mount and be positioned at a minimum of 700 mm (27.6 in.) above the ground. The reverse light shall be oriented to be visible to trailing vehicles and shine generally parallel to the ground.

B.10.4.3 - Reverse Alarm

Vehicles with a reverse gear shall be equipped with an audible reverse alarm. The reverse alarm shall sound when the vehicle is shifted to reverse gear and silenced when the vehicle is shifted out of reverse gear.

B.10.4.3.1 - Specification

Required reverse alarms shall be rated to meet the SAE standard J1741 or J994.

B.10.4.3.2 - Location

Required reverse alarms shall be mounted to the vehicle frame aft of the plane of the RRH.

B.10.5 - Instrumentation

Vehicles may be equipped with instrumentation to provide operational or performance information to the driver. All vehicle instrumentation must be included in the cost report.

B.10.6 - Data Acquisition

Vehicles may be equipped with data acquisition (data logging) systems. Data acquisition systems providing feedback to the driver must be included in the cost report. Data acquisition systems not providing data to the driver may be excluded from the cost report.

B.10.7 - Communication Systems

Teams are permitted to use radio-frequency (RF) communications systems. Any team using RF systems shall comply with federal, state, and local regulations based on the location of the event. At no point may a team's RF systems cause harmful interference to the voice or data systems in service of competition officials or emergency responders.

B.10.7.1 - Voice

Vehicles are permitted to use RF voice communications systems. RF Voice communication systems and equipment may be **excluded** from the cost report.

B.10.7.2 - Data

Vehicles are permitted to use RF data communications systems. All RF data communications systems and associated hardware may be **excluded** from the cost report. Exception: If a data communications system provides feedback to the driver, it shall be included in the cost report.

Article 11 - Tow Points

B.11.1 - General Requirements

Each vehicle must have towing hitch points at the front and rear, along its longitudinal centerline. These hitch points are used both for dynamic events and for vehicle recovery. Tow points must be attached to the vehicle frame and must allow for transmission of both longitudinal and lateral towing loads. Towing loads will be imparted to the tow point by way of hook or clevis. Tow points shall have sufficient strength to serve as a vertical lift point for the vehicle.

B.11.2 - Front Tow Point

Front tow points shall be constructed of tubular steel, not to exceed 31.75 mm (1.25 in.) and not less than 25.4 mm (1.0 in.) in diameter. Tubing thickness shall not be less than 0.89 mm (0.035 in.).

Front tow points shall be mounted no higher than the vehicle's SIM and not below the vehicle's LFS.

The front tow point shall be able to freely pass a gauge measuring 50.8 mm tall, 50.8 mm deep, and 203.2 mm wide (2.0 in. x 2.0 in. x 8.0 in.) behind the front tow point tube. See Figure B-59 for further information.

Note: Front numbers may not interfere with the tow point.

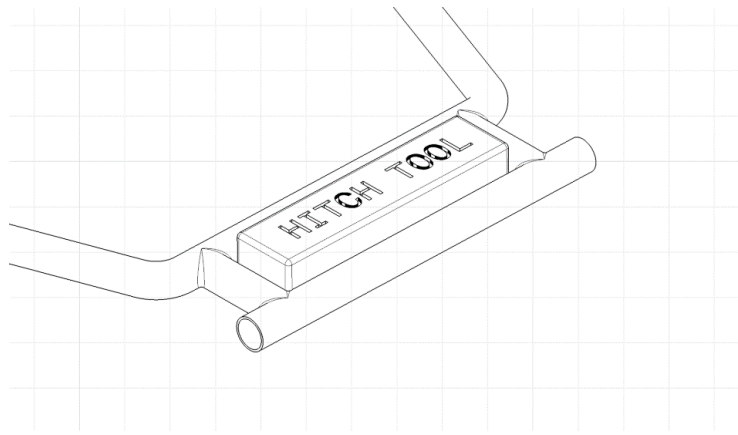

Figure B-59: Tow Point, Inspection Tool Fitment

B.11.3 - Rear Tow Point

Rear tow points shall be constructed from steel and meet the following dimensional requirements. No lightening features or cutouts other than the hole are permitted. See Figure B-61 for further information.

Dimension	Symbol	Minimum	Maximum
Tab Thickness	None	3.18 mm (0.125 in)	9.5mm (0.375 in.)
Hole Diameter	D	25.4 mm (1.0 in.)	31.75 mm (1.25 in.)
Hole-to-Tube Offset	X	19.0 mm (0.75 in.)	25.4 mm (1.0 in.)
Edge Distance	R	15.9 mm (0.625 in.)	25.4 mm (1.0 in.)
Width at Frame Connection	Y	76.2 mm (3.0 in.)	Unrestricted

Figure B-60: Tow Point, Table of Tow Point Dimensions

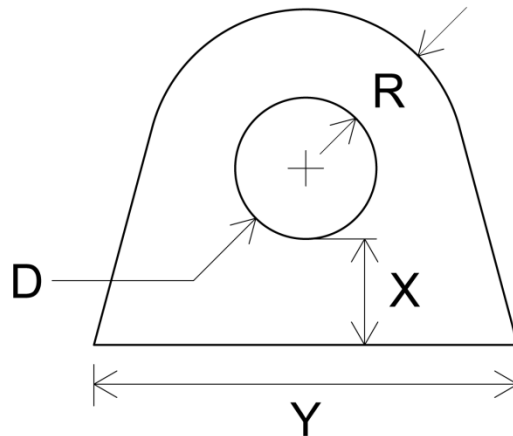

Figure B-61: Tow Point, Rear Tab Dimensions

B.11.3.1 - Fixed Rear Tow Point

Fixed rear tow points shall be fully welded to the vehicle frame along the base line, dimension Y. The tab may be vertically or horizontally oriented.

B.11.3.2 - Swivel Rear Tow Point

Swivel, or hinged, rear tow points shall be attached to the frame by way of a swivel mechanism. A swivel rear tow point may be horizontally or vertically oriented. The tabs for attaching the swivel mechanism to the frame shall be fully welded, a minimum thickness of 0.125 in thick, and have equal base line weld lengths totaling greater than or equal to dimension Y. Swivel pins shall be a graded fastener at least a 0.25 inch diameter meeting the requirements of B.12.1 - Fasteners.

Article 12 - Fasteners and Attachments

B.12.1 - Fasteners

Fasteners in the following vehicle systems shall meet the requirements of this article.

- Driver Harness
- Fuel System
- Fire Extinguisher
- Engine Kill Switches
- Tow Point Swivels

B.12.1.1 - Captive Fasteners

Fasteners shall be made captive by the use of the following:

- Nylon Locknuts
- Cotter Pins
- Safety Wire (for blind hole applications)

Welded nylon lock nuts, lock washers and/or thread sealants do not satisfy the requirements of this rule.

B.12.1.2 - Thread Projection

To provide for proper thread engagement in the lock nut, threaded fasteners shall have at least two (2) threads projecting past the end of the nut.

B.12.1.3 - Grade

Threaded fasteners shall meet or exceed one or more of the following strength grades:

- SAE Grade 5
- Metric Grade 8.8
- AN/MS specifications

Figure B-62 below depicts bolt markings meeting or exceeding requirements above.

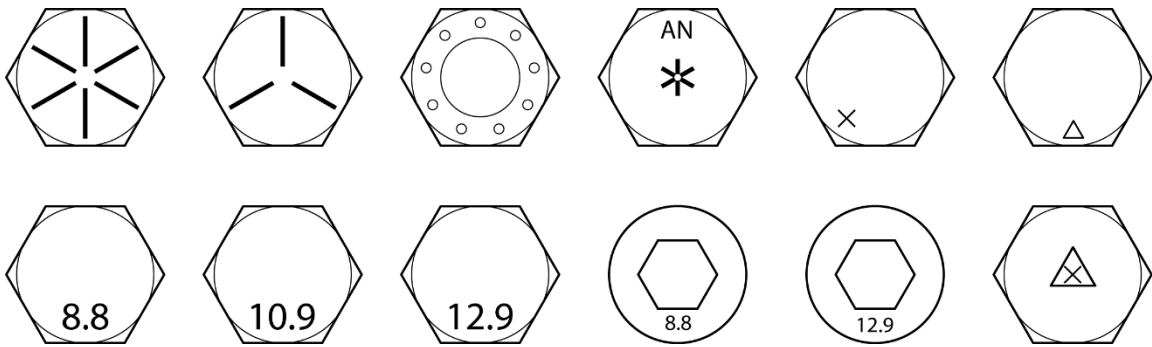

Figure B-62: Fasteners, acceptable markings

B.12.1.4 - Proof of Grade

For fasteners without markings as described above, proper documentation shall be supplied which requires a purchase receipt and manufacturer's specification (including markings) indicating the fastener strength exceeds or is equivalent to the requirements of B.12.1.3 - Grade.

Note: Teams using fasteners with readily visible grade markings will reduce their time in technical inspection.

B.12.1.5 - Unmarked or Custom Fasteners

Any threaded fastener (threaded rod, eye bolts, titanium bolts, etc.) that is unmarked, or does not have any markings as listed, must be documented by one or both of the following:

- A purchase receipt and manufacturer's documentation indicating the fastener meets or exceeds Grade 5 standards for that size.
- Equivalency calculations with a purchase receipt or test data showing that the fastener exceeds the strength for a Grade 5 fastener of the same size.

B.12.1.6 - Modified Fasteners

Fasteners which have been modified in any way other than: drilling for safety wire or shortening of the shank (threads) shall be proven to the NTI to meet the requirements of this article.

B.12.2 - Required Attachment Tabs

Tabs for attaching components in B.4.2 - Driver Harness, B.8.8 - Fire Extinguisher, and B.4.5 - Seats shall meet the requirements of this section.

B.12.2.1 - Dimensions

Threaded fasteners used with required tabs shall match the nominal diameter of the mounting holes in the mounting bracket. *For example, if a lap belt mounting tab is drilled for a 13 mm (0.5 in.) hole, the fastener and the frame lap belt tab shall be 13 mm (0.5 in.) in diameter.*

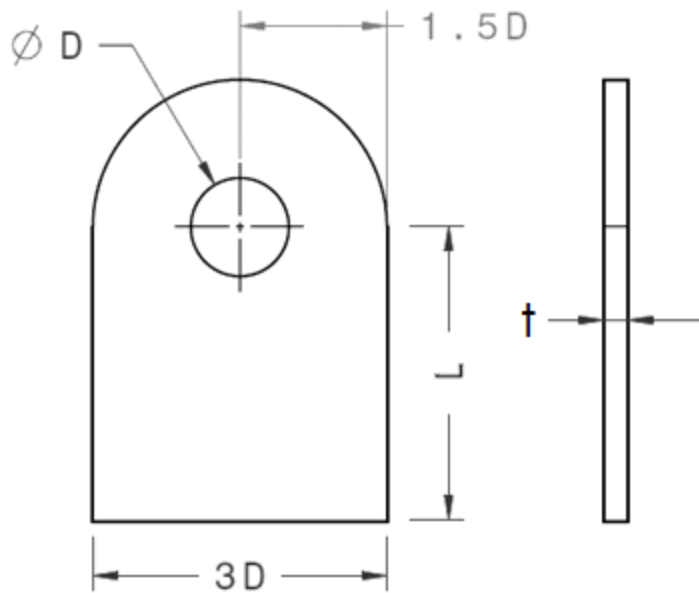

Figure B-63: Required Tab Drawing

Application	Nominal Bolt Size	Edge Distance	Base Width	Length	Thickness	Arrangement	Weld
	D, min.	E, min.	B, min.	L, max.	t, min.		
Lap Belt	7/16 in	1.5*D	3*D	2.0 in.	0.090 in	Double Shear	One Side
Anti Sub. Belt	7/16 in	1.5*D	3*D	2.0 in.	0.090 in	Double Shear	One Side
Fire Ext.	Check Bracket	1.5*D	3*D	3.0 in.	0.125 in	Single Shear	Both Sides
Seat	1/4 in	1.5*D	3*D	2.0 in.	0.125 in	Single Shear	Both Sides

Figure B-64 : Tab Requirements

B.12.2.2 - Construction

Tabs shall be constructed such that they do not visibly deform when loaded. Tabs shall be welded completely along the base line. Welding on one or both sides of the tab is indicated by Figure B-64 : Tab Requirements. The base line may be contoured to fit the surface the tab is welded to. Tab length will be evaluated as the distance between the mid-point of the base line and the hole center. No cutouts or other weight saving features may be applied to the required tabs.

Article 13 - Vehicle Identification and Markings

B.13.1 - Vehicle Number Assignment

Vehicle numbers are assigned by SAE as part of the online registration for all U.S. and Canadian Baja SAE® competitions. Numbers shall be assigned by criteria determined by SAE CDS staff. Assigned numbers may be found on the Baja SAE® website in the “Registered Team List” for each competition. For competitions outside the U.S. and Canada, vehicle numbers will be assigned by the respective organizers.

B.13.2 - Transponders

For U.S. and Canadian Baja SAE® competitions, a transponder system is used for timing and scoring. All Baja SAE® vehicles are required to have a transponder. Vehicles must carry a functional, properly mounted and fully charged transponder of the specified type. Vehicles without the specified transponder will not be allowed to compete in any event for which a transponder is used for timing.

B.13.2.1 - Required Transponder

All vehicles must be equipped with at least one MYLAPS rechargeable transponder. The only acceptable transponder types are:

- Classic MX
- Flex MX
- X2 MX
- TR2 MX

Subscriptions for Flex MX or X2 MX transponders must be up-to-date and all Flex MX and X2 MX transponders must have been activated prior to Transponder Check at Technical Inspection. The timing system is capable of recording two transponder identifications per vehicle; therefore, a second transponder may be mounted as a backup if desired.

Refer to the table or visit <http://www.mylaps.com> for more information.





Allowed Transponders					
Transponder Name	MX Classic	MX Flex	X2 MX Rechargeable	X2 MX Direct Power	TR2 MX
Picture					
Price Model	One Time Purchase	1, 2 or 5 Year Subscription	1, 2 or 5 Year Subscription	1, 2 or 5 Year Subscription	1, 2 or 5 Year Subscription
Sales Availability	No Longer Available	No Longer Available	No Longer Available	Currently Available	Currently Available
Renewal Availability	-- NA --	1, 2 or 5 Year	1, 2 or 5 Year	1, 2 or 5 Year	1, 2 or 5 Year
MyLaps' End of Support	1-6-2017	1-6-2017	12-1-2021	Ongoing	Ongoing
MyLaps' End of Service	1-6-2019	1-6-2019	12-1-2023	Ongoing	Ongoing
Insurance Included	No	Yes, With Subscription	Yes, With Subscription	Yes, With Subscription	Yes, With Subscription
Warranty Included	3-year Limited Warranty	Unlimited warranty	Unlimited warranty	Unlimited warranty	Unlimited warranty
Mounting Type	Classic Quick Release Clip	Classic Quick Release Clip	X2 Quick Release Clip	Direct Mount + Cable Harness	TR2 Quick Release Clip
Power Source / Time on Battery	Rechargeable / 4 Days	Rechargeable / 5 Days	Rechargeable / 5 Days	Direct Power (12V) With Built in Battery Backup	Rechargeable / 5 Days
Time Needed to Charge	16 Hours	16 Hours	4 Hours	-- NA --	5 Hours
Charger Type	<u>Black</u> 12V Cradle	<u>White</u> 5V USB Cradle	5V USB X2 RaceKey	-- NA --	5V USB <u>TR2</u> Cradle

Figure B-65: Table of transponder information

B.13.2.2 - Purchase

All teams are responsible for purchasing their transponder(s) directly through MyLaps.

<http://www.mylaps.com>

B.13.2.3 - Mounting

All vehicle transponders shall be mounted in the proper location, correctly oriented, and using sufficient fastening methods.

B.13.2.3.1 - Orientation

The transponder shall be installed vertical to the frame in the orientation shown in figure. The transponder shall also be oriented so the transponder number can read “right-side up.”



Figure B-66: Transponder Orientation

B.13.2.3.2 - Location

The transponder shall be mounted on the right side of the vehicle, forward of the seat, and preferably within the lower horizontal plane of the front suspension. The transponder shall be no more than 61 cm (24 in) above ground level.

The transponder shall have an open, unobstructed path between the antenna on the bottom of the transponder and the ground.

Caution: Metal and carbon fiber may interrupt the transponder signal.

Note: The transponder signal will normally transmit through fiberglass and plastic.

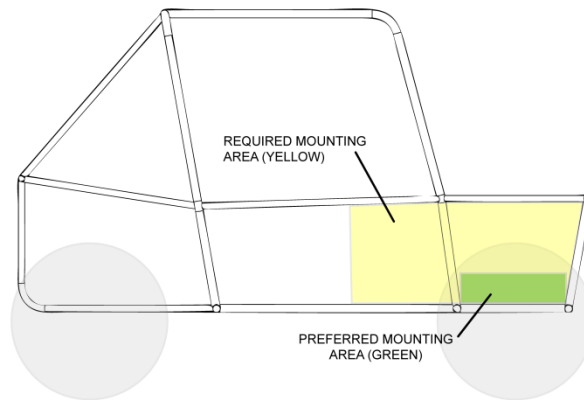

Figure B-67: Transponder, Mounting Location

B.13.2.3.3 - Fastening

Each transponder is supplied with a mounting bracket. Teams are advised to weld a small plate to their frame to attach the transponder mounting bracket. The bracket can be attached with rivets, cable ties or bolts.

Note: Attaching the bracket with 4 mm (0.160 in.) pan-head or flat-head bolts with lock nuts or lock-wire is suggested.

B.13.2.3.4 - Interference

RF systems transmitting voice and/or data can cause harmful interference with the signal transmitted by the transponder. Care should be taken when designing, fabricating, or maintaining RF systems near the transponder.

Note: The transponder equipment operates at a frequency of 3.59 MHz.

B.13.3 - Vehicle Numbers

Vehicle numbers are critical for the organizers and officials to positively identify team vehicles. Teams must design numbers to be visible in all race conditions or keep them clean and conspicuous. Numbers shall not be obscured by any other portion of the vehicle.

Caution: Numbers that are not easily read may be black flagged and might not be scored during the endurance event.

B.13.3.1 - Required Numbers

Three sets of primary numbers are required to be securely affixed to the car. The vehicle's number shall be readily visible from the left side, right side, and the front of the vehicle and strongly contrast with the number's background color. No leading zeros are allowed.

B.13.3.2 - Required Font

Vehicle numbers shall be displayed in either the "Highway Gothic Regular" font or "Century Gothic Bold" font. No other fonts are permitted. Examples of both fonts are given below.

Highway Gothic: 1 2 3 4 5 6 7 8 9 0

Century Gothic Bold: 1 2 3 4 5 6 7 8 9 0

Figure B-68 : Approved vehicle number font examples.

B.13.3.3 - Location

B.13.3.3.1 - Side Numbers

Side numbers, mounted to the left and the right sides of the vehicle, shall be mounted above the SIM and aft of the plane of the RRH. Side numbers shall not be visually obstructed by any part of the vehicle.

B.13.3.3.2 - Front Number

The angle of the plane of the front-facing numbers, when affixed to the vehicle above the SIM, shall be less than or equal to 45 deg. from vertical.

The angle of the plane of the front numbers, when affixed to the vehicle below the SIM, shall be less than or equal to 15 deg. from vertical.

B.13.3.4 - Orientation

Numerals shall be aligned along a common horizontal line, and the entire number panels shall be mounted in a horizontal orientation (+/- 3.0 degree tolerance) to facilitate fast vehicle identification. The number panels shall have 25.4 mm (1.0 in.) spacing between numerals.

B.13.3.5 - Number Size

The primary cutout numbers must be at least 152 mm (6.0 in) high, dimension "H" in Figure B-69. The primary cutout numbers shall have a stroke width in proper proportion to the font design for the given character height. The primary cutout numbers shall be mounted such that the projecting face is a minimum of 13 mm (0.5 in) from the background panel.

Note: Avoid sharp edges or points on the inner and outer edges of the cutout numbers.

B.13.3.6 - Backing Panel

Each number on the vehicle shall have a highly contrasting background to facilitate easy reading. The edges of the backing panel shall be no less than 25.4 mm (1.0 in.) from the edge of the numbers (dimension "D" in Figure B-69). Numbers may be outlined to provide enhanced contrast. Number backing panels must be securely fastened to the vehicle frame.



Figure B-69: Vehicle Numbers, Example

B.13.3.7 - Number Color

Teams are free to select their own number and backing panel colors. Number colors must be a bright color against a highly contrasting background and facilitated fast vehicle identification. The number backing panel shall be all one color and all numerals shall be of matching color. See Figure B-69.

B.13.4 - SAE International Logo

Two (2) SAE International logos must be displayed on the vehicle in prominent locations. These will be distributed during registration at the competition.

B.13.5 - Sponsor Identification

Teams may display advertising from their vehicle's sponsors, provided it is in good taste and does not conflict with the vehicle's number. SAE International may require all entrants to display advertising from the competition sponsors.

B.13.6 - RFID Tags

Baja SAE utilizes an RFID tag system as a secondary identification and lap counting system throughout the competition. The implementation of the RFID tag system improves the lap counting accuracy for all teams.

B.13.6.1 - Required RFID Tag

Baja SAE utilizes Omni-ID Exo 800 tags. See Figure B-70 for dimensional and mounting information. Only SAE-issued RFID tags may be used. No other RFID tags are permitted. Teams will be issued RFID tags at their first competition where RFID tags are implemented. Teams shall keep their issued RFID tag for all future competitions. Teams requiring replacement RFID tags must contact SAE to purchase a replacement tag.

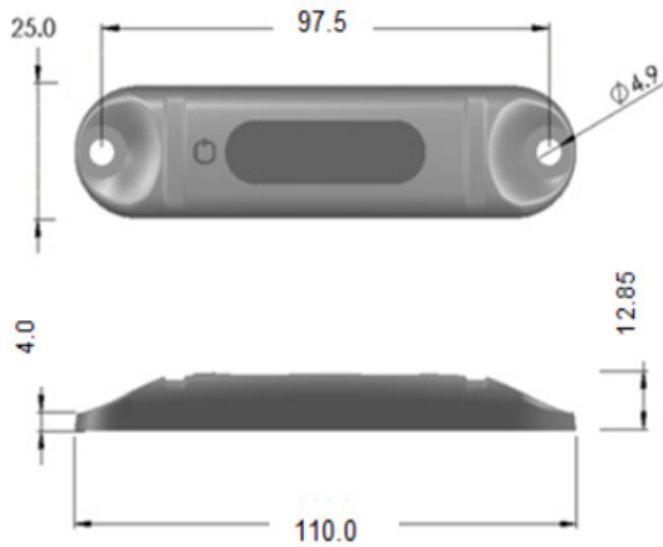

Figure B-70: RFID Tag Dimensions

B.13.6.2 - Mounting

B.13.6.2.1 - Orientation

RFID tags shall be horizontally oriented. RFID Tags shall face outward to the right side of the vehicle. See Figure B-71.

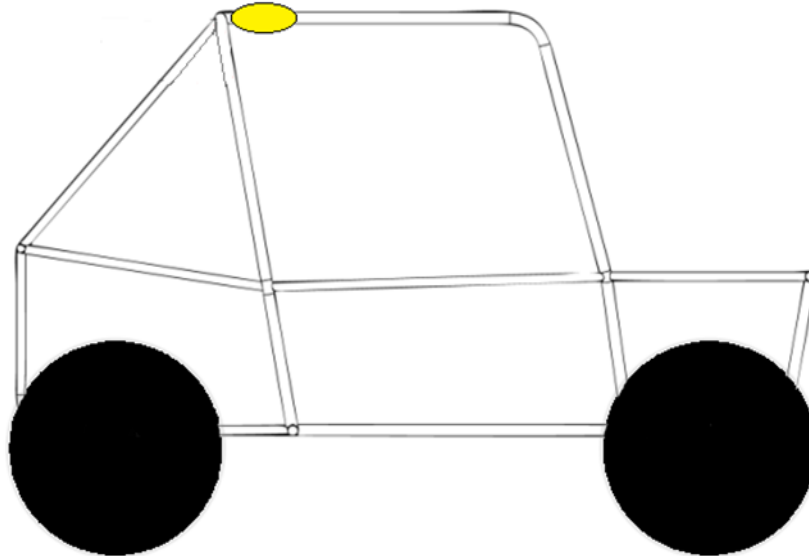

Figure B-71: RFID tag location

B.13.6.2.2 - Location

RFID Tags shall be mounted to the right side of the vehicle, along the RHO, forward of point BR, and adjacent to point BR. See Figure B-71.

B.13.6.2.3 - Fastening

RFID Tags shall be affixed to the vehicle by one of the following methods:

- Bolted to the frame member - tabs are sufficient for bolt and/or rivet fasteners as long as a flat face is still oriented outward and the tab extends all of the way behind the RFID tag. Note: the tab serves as a wave guide.
- Riveted to the frame member - tabs are permitted.
- Plastic cable ties - Note: care should be taken to limit the tags ability to rotate around the tube.

B.13.6.2.4 - Interference

RFID tags utilize the UHF portion of the radio spectrum from 890 to 940 MHz and utilize the EPC Class 1 Gen2 Protocol. Teams are not permitted to operate radio equipment that causes harmful interference with the SAE RFID tag reader system. RFID Tags should have direct, line-of-sight path to the right side of the track. RFID tags shall not be covered with any material or otherwise obscured. RFID tags may be painted with non-metallic paint.

B.13.6.2.5 - Modification

Modification of the RFID tag is not permitted. RFID tags are IP68 rated and do not require any external protection from water, dust, or mud.

Part C : Static Events

The content of section C applies to US and Canadian Events for the 2021 competition year.

Article 1 - Scoring Summary

All teams are expected to participate in all static judging and may be excluded from dynamic events if they do not participate in static events.

Static Event	Points
Design Evaluation	150
Cost Evaluation	100
Business Presentation	70
Total	320

Figure C-1: Static Events, Table of Points

Article 2 - Technical Inspection

C.2.1 - Overview

All Baja SAE® vehicles shall pass a technical inspection before they are permitted to operate under power. The inspection will determine if the vehicle satisfies the requirements and restrictions of the Baja SAE® rules. If vehicles are not ready for technical inspection when they arrive at the inspection site, they will be sent away. Teams sent away must prepare their vehicle accordingly and return to the inspection site ready for inspection. Any vehicle may be re-inspected at any time during the competition and correction of any non-compliance will be required.

C.2.2 - Procedure

Technical inspection will consist of three (3) separate parts as follows:

C.2.2.1 - Engine Inspection

Kohler Technical Representatives will set the governors of all vehicles. Vehicles must be presented for governor setting with the engine output shaft bare and free of any objects, the drivetrain disconnected from the engine, the throttle cable disconnected from the engine, and functioning engine kill switches. Each vehicle engine must be inspected by Kohler technical staff that will:

- Confirm the engine's compliance with the rules and
- Set the governor to the specified engine speed (3,800 RPM)

The engine inspection (with the engine installed in the vehicle) must be passed, before a team may apply for Technical Inspection.

C.2.2.2 - Technical Inspection

Each vehicle will be inspected to determine if it complies with the requirements and restrictions of the Baja SAE® rules. Each team must bring the following items to inspection:

- Frame Material Documentation: Receipts documenting the materials purchased, or otherwise acquired, and used to build the frame.
- Roll Cage Specification Sheet: A signed and completed copy of the Roll Cage Specification Sheet
- Technical Inspection Sheet: A properly completed Technical Inspection Sheet, see www.bajasae.net/go/downloads
- Drivetrain Check Sheet: A properly completed Drivetrain Check Sheet
- Drivers Present: All drivers must be present at technical inspection.

The Technical Inspection must be passed before a team may apply for Dynamic Brake Check.

C.2.2.3 - Dynamic Brake Check

At Dynamic Brake Check, both the external and cockpit kill switches will be tested for functionality before the vehicle is allowed to proceed. If both switches pass the test, then the vehicle will be dynamically brake tested. Each vehicle must demonstrate its ability to lock all four wheels and come to rest in an approximately straight line after acceleration run specified by the inspectors. If a vehicle fails to pass any part of the inspection, it must be corrected and brought into compliance with the rules before the vehicle is permitted to operate.

C.2.3 - Preparation

Teams presenting Technical Inspection Sheets that are incomplete, inaccurate (i.e. do not correspond to the actual condition of the vehicle), are found to have four (4) or more items not in accordance with the rules, or do not represent a serious effort at pre-inspection will be denied inspection at that time and sent back to the end of the inspection line.

C.2.4 - Technical Inspection Sheet

C.2.4.1 - Pre Inspection Requirements

Before bringing their vehicle to technical inspection each team must

- Pre-inspect the vehicle for compliance with the rules
- Complete the official technical inspection sheet (available at www.bajasae.net/go/downloads)
- Have the completed inspection list signed by the faculty advisor and team captain. Required reading includes for news and important information includes: www.bajasae.net/go/news.

C.2.4.2 - Inspection Sheet Version

Teams must download the most current version of the technical inspection sheet within two weeks of the competition and thoroughly inspect their vehicle in accordance with the technical inspection sheet.

C.2.5 - Inspection Stickers

A multi-part inspection sticker will be issued in sections to each vehicle as each of the three parts of technical inspection is completed. The inspectors will place the inspection sticker on the right side of the firewall above the driver's shoulder. The inspection sticker must remain on the vehicle throughout the competition. Vehicles without all parts of the inspection sticker may not be operated under power.

Any or all parts of the inspection sticker may be removed from any vehicle by the NTI that has been damaged or which is reasonably believed may not comply with the rules.

C.2.6 - As Approved Condition

C.2.6.1 - Modifications

Once a vehicle has passed technical inspection its configuration may not be modified. All accessory components such as roofs, wings, bumpers, etc. are considered part of the configuration and must remain on the vehicle at all times.

C.2.6.2 - Repairs

Approved vehicles must remain in “as-approved” condition throughout the competition. Any repairs of a part that is not identical as the broken part must be approved prior to the repair.

C.2.6.3 - Non-Matching Components

Non-identical parts not approved will be subject to an appropriate performance penalty.

C.2.6.4 - Tuning

Minor adjustments permitted by the rules and normal vehicle maintenance and tuning are not considered modifications.

C.2.7 - Penalties

Teams not passing Technical Inspection by 2:00 PM local time on the dynamic event day shall have their cost event score changed to zero (0) points.

Article 3 - Design Evaluation

C.3.1 - Objective

The objective of the engineering design evaluation event is to evaluate the engineering effort that went into the design of the vehicle and how the engineering meets the intent of the market, as detailed in the A.1.3 - Baja SAE Program Objective and the A.1.4 - Design Subject. Students will be judged on the creation of design requirements and the ability to meet those requirements, computer aided drafting, analysis, testing and development, manufacturability, serviceability, system integration and how the vehicle works together as a whole. Each of these parts of the engineering product development cycle will be judged within the following subsystems: Suspension, Steering, Brakes, Drivetrain/Powertrain, 4WD/AWD, and Chassis and Ergonomics.

The vehicle that illustrates the best use of engineering to meet the design goals and the best understanding of the design by the team members will win the design event.

Teams are reminded that Baja SAE® is an engineering design competition and that in the Engineering Design Event, teams are evaluated on their design. Components and systems that are incorporated into the design as finished items are not evaluated as a student designed unit, but are only assessed on the team's selection and application of that unit. For example, teams that design and fabricate their own shocks are evaluated on the shock design itself as well as the shock's application within the suspension system. Teams using commercially available shocks are evaluated only on selection and application within the suspension system.

C.3.2 - Metrics

The engineering design event student guide and score sheet can be found at www.bajasae.net/go/downloads.

The engineering design event consists of two parts: Design Evaluation and a Design Review Briefing (DRB) that will be used as a part of the design evaluation.

C.3.3 - Design Documents

C.3.3.1 - Overview

The design evaluation judging will start with submission, before the event, of a Design Review Briefing (DRB). The DRB will be reviewed by the design judges who will ultimately judge the team and vehicle during the Design Evaluation Event.

C.3.3.2 - Document Submittal

The DRB must be submitted electronically in Adobe Acrobat Format (PDF). The document must be a single file (text, drawings and optional content are all inclusive). The maximum size for the file is 25 MB.

C.3.3.3 - Format

The DRB template must be followed and the template can be found on the BajaSAE.net website.

C.3.4 - Design Evaluation

The design judges will evaluate the engineering effort based upon the team's DRB, the design presentation, responses to questions, and an inspection of the vehicle (if applicable).

C.3.4.1 - Design Score Sheet

The Design Judging Score Sheet is available at www.bajasae.net/go/downloads. The judges strongly urge all teams to read and study the score sheet and all other documents related to design judging that are available on the website.

C.3.4.2 - Support Material (Onsite Events)

Teams are encouraged to bring with them to Design Evaluation any photographs, drawings, plans, charts, example components, or other materials that they believe are needed to support the presentation of the vehicle and the discussion of their development process. Use of laptop or notebook computers, posters, and binders is highly encouraged, but projectors may not be used. The burden of proof is on the students and the design score will reflect not only the student's ability to properly articulate and communicate their engineering effort, but must also be backed up by sufficient documentation.

C.3.4.3 - Judging Format

The actual format of Design Evaluation may change from year to year as determined by the organizing body and can be found at www.bajasae.net/go/downloads.

Design Evaluation is typically organized as follows:

- Initial judging of all vehicles
- Final judging ranking the top 3 to 10 vehicles.

C.3.4.4 - Design Finals

C.3.4.4.1 - Overview

The purpose of Design Finals is to reward and call attention to those vehicles judged to have the best engineering designs. Design Finals are held after the conclusion of Design Evaluation so that the finalists may be chosen, and then judged as described in section C.3.4.4.2 - Presentation Format. The number of finalists may vary from as few as three to as many as ten, as determined by the number of entries and the results of Design Evaluation.

C.3.4.4.2 - Presentation Format

The Design Finals format and timing may change from year to year as determined by the organizing body. The Design Finals format, timing, and instructions will be released in a General Notice posted on the BajaSAE.net website. One or more team members may give the presentation to the judges. Any team member on the presentation floor may answer the questions from the judges even if that member did not speak during the presentation. For onsite events, it is recommended teams bring a laptop computer, binders, or posters to communicate their design work. No projectors will be allowed.

C.3.5 - Design Comparison Requirement

Teams with vehicles that finished in a top ten position overall in any of the previous year's Baja SAE® competitions are classified as having created a "successful design." Teams that created such successful vehicles are required to provide a comparison, using the template described below, of their current design with their previous year's design, even if the current design is entirely new. Teams shall be prepared to present their design comparison when requested by the design judges. If the judges find that the design changes are not significant, not supported by a detailed analysis, or not been sufficiently documented, then a penalty of up to 150 points may be assessed against the design score.

C.3.5.1 - Redesign Comparison Document

The design comparison report must follow the template found at www.bajasae.net/go/downloads and should be submitted by way of the instructions in the template file.

The documentation should be a year to year comparison of the major structure and/or systems of the vehicle and may consist of any, or all, of the following, supported by appropriate captions:

- 1) Plans
- 2) Drawings
- 3) Photographs

Design changes to correct failures of the previous design should be accompanied by a thorough analysis of why the failure occurred and the theoretical data supporting the new design, etc.

C.3.6 - Scoring

The engineering design event will be worth 150 points.

The judges may at their discretion award the highest placing team less than the maximum noted above. Design finalist may also receive bonus points that could make their scores higher than the maximum noted above.

Article 4 - Cost Evaluation

C.4.1 - Objective

The purpose of the Cost Event is to provide teams an opportunity to show the cost/benefit design decisions used in the prototype vehicle. The Cost Event aims to represent a comparable model for each team to be measured against. Revisions in the Cost Event implemented for the 2018 Competition Season are an effort to streamline the costing and evaluation processes and provide a more comparable and fair costing model.

For up-to-date information on the Cost Event, please refer to <http://www.bajasae.net/go/cost> and check back through the fall as this information is updated.

C.4.2 - Cost Report

The Cost Report will be summarized in an online format where teams can complete their overall BOM (Bill of Materials) with material and manufacturing costs.

C.4.2.1 - Costing Sheets

The core of the report is the series of costing sheets. Implemented in 2018, the format of these sheets will follow the online format. See <http://www.bajasae.net/go/cost> for descriptions of these sheets and the instructions on how to use them.

C.4.2.2 - Cost Documentation

Cost Documentation is required for all purchased components and material costs. Implemented in 2018, this documentation will come from a common database of material and component costs. These items may be specific or may be generalized into a cost category of material/components. If a team's purchased material/components are not in the common database, the team may submit an "Add Item Request" for their specific material or component for approval. Once submitted and approved, that material is available for all teams to use. See <http://www.bajasae.net/go/cost> for more detail on this database and how to use it in the Costing Sheets.

C.4.2.3 - Cost Report Submission

Teams must submit a cost report at the cost report deadline. This report must be as complete as possible at this deadline. It will be compared to the cost adjustment report submitted prior to each competition. If there is a difference in the prototype cost of more than 20% plus or minus, there will be a twenty-five (25) point penalty assessed to the team in the cost event. If the prototype cost report changes more than 40% plus or minus, the cost report will be deemed incomplete and team will be excluded from the prototype cost competition and will receive zero (0) points for the cost competition.

C.4.2.4 - Cost Reduction Report

Teams must submit a report with up to two (2) ideas for cost reduction. Each idea will be worth up to 10 points. The format of the report and the scoring matrix will be posted at <http://www.bajasae.net/>.

C.4.3 - On Site Evaluation

Teams may be required to meet with a cost auditor during the competition to ensure that the vehicle presented at the competition matches with the BOM submitted in the Cost Report.

C.4.3.1 - Cost Audit

The judges may increase costs and/or fabrication times if they believe that the figures submitted are below current prices for the item, source, or process involved. All items found by the judges will be added to prototype cost at three (3) times the price of items found missing or below current prices. Prices or times that are higher than the judge expects will not be corrected. Teams that have entered multiple competitions will have penalties found during cost audit carried over to each subsequent competition that the team is entered. Mathematical errors will be penalized. Reports that are highly inaccurate, highly incomplete, or in which the costs cannot be substantiated, may be rejected in their entirety and scored accordingly. Teams that are required to bring their car to on-site cost judging must do so by their scheduled appointment. Failure to report by the scheduled appointment time will result in an automatic zero for the event. If teams need to reschedule their appointment, it must be done prior to their appointment. Teams selected for cost audits will be notified by SAE International at registration.

C.4.3.2 - Additional Team Review

The judges reserve the right to review with any team during the competition the accuracy of their BOM relative to the vehicle brought to competition. This includes teams who were chosen for audits as well as teams who were not originally chosen and notified.

C.4.4 - Scoring

The Cost Evaluation event will be worth 100 total points.

C.4.4.1 - Prototype Cost

The Prototype Cost score is a maximum of 80 points of the available 100 points of the total cost score and is based upon the Prototype Cost, as adjusted by the judging process, as compared with other vehicles at the competition.

Prototype Cost score will be calculated as follows:

$$S_{cost} = 80 \times \frac{C_{max} - C_{team}}{C_{max} - C_{min}} + \textit{Bonus Points}$$

Where:

C_{team} Vehicle cost, as corrected

C_{min} lowest vehicle cost, as corrected

C_{max} highest vehicle cost, as corrected

Bonus points awarded per C.4.2.4 - Cost Reduction Report.

C.4.4.2 - Cost Eligibility

Upon review of the data, the cost judge reserves the right to disqualify cost that has not been sufficiently validated (i.e. either through lack of documentation or outdated receipts), are determined to not be complete based on review, or are outside a reasonable level of cost based on the other cars in the competition (i.e. either too high or too low).

The burden of proof is on the students and the cost score will reflect not only the student's ability to properly articulate and communicate their engineering effort, but must also be backed up by sufficient documentation.

Article 5 - Business Presentation (BP)

C.5.1 - Objective

The Business Presentation event evaluates the team's ability to develop and deliver a comprehensive business, logistical, production, or technical case that will convince outside interests to invest in the team's concept.

C.5.2 - Concept

Concept information will be available on the BajaSAE.net website. BP concepts may change for each competition. The content of a team's BP shall match the requirements of the concept. The team's BP shall relate specifically to the vehicle as entered for the specific competition. Teams should assume that the judges represent different areas, including engineering, production, marketing, and finance. Teams should assume that not all judges may be engineers. The BP location and setting will be communicated on the Baja SAE website.

C.5.3 - Tardiness

Teams that fail to make their presentation during the assigned time period will receive zero points for the BP event.

C.5.4 - Submissions

The BP concept may require information to be submitted prior to the event. Specific details will be included in the BP concept information on the BajaSAE.net website. Submissions may be graded as part of the BP event score. Pre-event submissions will be subject to penalties as described in A.6.2.7 - Failure to Meet Deadlines.

C.5.5 - Format

BP will operate in a hybrid model consisting of a Request for Proposal (RFP) submission, virtual presentations, and onsite finals presentations.

One or more team members will present the BP to the judges. All team members who will give any part of the presentation, or will respond to the judges' questions shall be in the local presentation area at the time the presentation starts, and shall be introduced and identified to the judges. BP's will be time limited, and judges will stop any presentation exceeding the time limit. Judges will not interrupt the BP for questions. Any questions will only be asked by the judges immediately following the presentation.

C.5.5.1 - Virtual Presentations

All teams will submit a Request For Proposal (RFP) submission to the BajaSAE.net website. BP judges will review all submissions and choose a portion of submissions to present live in the virtual presentations round. All details on submission format, length, content, and timing will be published on the Baja SAE website.

C.5.5.2 - Onsite Presentations

Teams selected from the RFP submission will virtually present their BP to a panel of judges and their score will apply to all onsite competitions they are attending. Teams will be ranked only against teams

attending the same competition. The software platform for virtual presentations will be defined and communicated by the organizing body. The virtual presentations will take place before any onsite events. Student teams may be required to submit a judge pre-read document ahead of their presentation. If so, teams will be notified ahead of time on the deadline and format.

C.5.6 - Equipment

Any and all audio-visual and/or communication equipment required for a team's presentation shall be arranged and provided for by the presenting team.

C.5.7 - Evaluation Criteria

Presentations will be evaluated on content, organization, visual aids, delivery, and the team's response to the judges' questions. The actual quality of the prototype itself will not be considered as part of the presentation judging. Further information is available on the BajaSAE.net website.

C.5.8 - Scoring

The BP event is worth 70 points. At the judge's discretion, the highest placing team may receive less than the maximum score noted above.

C.5.8.1 - Bonus

In-person BP finals will take place at each onsite event for the top teams to potentially earn bonus points based on their performance. BP finalists may receive up to 7 bonus points that may make their scores higher than the maximum noted above.

Part D : Dynamic Events

The dynamic events are intended to determine how Baja SAE® vehicles perform under a variety of conditions. Note that the organizers may modify the dynamic events to address local conditions, weather or resources. The content of Section D applies to US and Canadian Events for the 2024 competition year.

Article 1 - Scoring Summary

Dynamic Event	Points
Acceleration	70
Hill Climb or Traction	70
Land Maneuverability	70
Suspension or Rock Crawl	70
Endurance	400
Total	680

Figure D-1: Dynamic Events, Table of Points

D.1.1 - Bonus Points

No bonus points are available for the 2024 competition.

Article 2 - Safety Check

At the staging area for each dynamic event, a safety check will be completed. This safety check is intended to verify the vehicle is safe to drive on the dynamic event course in its current configuration. This safety check may include, but is not limited to:

- Driver Restraint
- Kill Switch Functionality
- Brake System Check

Failure of this safety check will result in teams being required to return to their paddocks to make sufficient repairs before participating in further competition.

Article 3 - Practice

D.3.1 - Objective

Organizers may or may not provide a practice track to teams. A practice track allows teams to test or tune their vehicle within the limits of the rules.

D.3.2 - Course

If the organizer provides a practice track, the course length and features are at the organizer's discretion.

D.3.3 - Procedure

After a safety check, vehicles are signaled to enter the practice track. After a predetermined time set by the track worker, the vehicle is signaled to exit the practice track.

D.3.4 - Penalties

Teams may be signaled to exit the practice track or barred from using the practice track if the track worker or competition officials observe unsafe conditions or behaviors.

D.3.5 - Signals and Signage

See D.9.9 - Signals and Signage.

D.3.6 - Scoring

There is no score awarded for practice.

Article 4 - Acceleration

D.4.1 - Objective

The Acceleration Event is designed to measure each vehicle's ability to come up to speed quickly from a standing start.

D.4.2 - Course

Acceleration is measured as the time to complete a 30.48 m (100 ft.) or 45.72 m (150 ft.) flat, straight course from a standing start. The course surface may vary from pavement to loose dirt. The choice of course length and surface is at the organizer's discretion.

D.4.3 - Procedure

After a safety check, vehicles are positioned at the start line of the course. The track worker will check that the driver is ready to begin. Once the driver is ready, the track worker will signal the driver to proceed down the course. After completing the run on the course, the vehicle will be directed to the course exit.

Each vehicle may make two (2) runs on the course.

D.4.4 - Penalties

- Stall At Start – Run DQ
- False Start – Run DQ
- Driving off Course – Run DQ

The organizer may modify the penalties imposed for different violations to account for differences in the length or design of specific event courses.

D.4.5 - Signals and Signage

See D.9.9 - Signals and Signage.

D.4.6 - Scoring

The maximum number of available points for the acceleration event is 70 points.

Scoring will be based on the better of the two attempts. Timing will be performed with an electronic timing system.

The following equation will be used for the acceleration score (S_{ac}):

$$S_{accel} = 70 \times \frac{t_{max} - t_{run}}{t_{max} - t_{min}}$$

Where:

t_{min} is the lowest (fastest) time by any vehicle

t_{run} is the time recorded for a vehicle's run to be scored.

t_{max} is the minimum of the following:

- The longest (slowest) time by any vehicle, or
- 1.5 times t_{min}

Vehicles with acceleration times that are more than 1.5 times that of the fastest vehicle will not receive a score for this event. Teams attempting the event, but exceeding the time limit will be classified as "Excess Time."

Article 5 - Traction

D.5.1 - Objective

This event tests the vehicle's relative ability to climb an incline from a standing start or pull a designated object, e.g. progressive weight skid, vehicle, or chain along a flat surface.

D.5.2 - Course

The traction event may take place on a straight or curved course. The organizer will determine the hill elevation (height), hill inclination (grade), and hill surface or object to be pulled.

D.5.3 - Procedure

After a safety check, vehicles are positioned at the start line of the course. The track worker will check that the driver is ready to begin. Once the driver is ready, the track worker will signal the driver to proceed down the course. After completing the run on the course, the vehicle will be directed to the course exit.

Vehicles may not continue the attempt after they have stopped on the course.

D.5.4 - Penalties

Driving Off Course – Score as maximum progress at point of exiting the course.

D.5.5 - Signals and Signage

See D.9.9 - Signals and Signage.

D.5.6 - Scoring

The maximum number of available points for the traction event is 70 points.

Scoring will be based on the better of the two attempts. Timing will be performed with an electronic timing system. If a vehicle cannot complete the course and get a time, it will be scored on the distance that it

travels before stopping. Once the vehicle stops moving forward the attempt is over and the attempt is scored for distance at that point.

D.5.6.1 - Method 1 (Different Distances)

If none of the vehicles are able to complete the course, then:

The following equation will be used for the traction score (S_{tr}):

$$S_{tr} = 70 \times \frac{d_{run} - d_{min}}{d_{max} - d_{min}}$$

Where:

d_{min} is the shortest distance by any vehicle

d_{run} is the distance traveled for the vehicle to be scored.

d_{max} is the longest distance by any vehicle.

D.5.6.2 - Method 2 (Fixed Distance, All Succeed)

If there is (a) a set maximum distance and (b) all teams succeed in completing a full distance hill or pull, then the score will be based on the time for the full distance.

The following equation will be used for the traction score (S_{tr}):

$$S_{tr} = 70 \times \frac{t_{max} - t_{run}}{t_{max} - t_{min}}$$

Where:

t_{min} is the lowest (fastest) time by any vehicle

t_{run} is the time recorded for a vehicle's run to be scored.

t_{max} is the minimum of the following:

- The longest (slowest) time by any vehicle, or
- 2.5 times t_{min}

D.5.6.3 - Method 3 (Fixed Distance, Some Succeed)

If there is (a) a set maximum distance and (b) at least one team climbs the hill or makes a full pull and others do not, then the vehicles going the full distance (Group I) will be scored based on time and the vehicles that fail to climb the hill or make a full pull (Group II) will be scored based on distance.

Group 1

$$S_{tr,1} = 70 \times \frac{t_{min}}{t_{run}}$$

Where:

t_{min} is the lowest (fastest) time by any vehicle

t_{run} is the time recorded for a vehicle's run to be scored.

Group 2

$$S_{tr,2} = \min(S_{tr,1}) \times \frac{d_{run}}{d_{course}}$$

Where:

d_{run} is the distance recorded for a vehicle to be scored.

d_{course} is full length of the course to be run by the vehicle.

Article 6 - Maneuverability

D.6.1 - Objective

Maneuverability is designed to assess each vehicle's agility and handling ability over off-road terrain. Teams will attempt to maneuver through the course with a minimum time.

D.6.2 - Course

The course may consist of a variety of challenges at the organizer's option, possibly including tight turns, pylon maneuvers, ruts, bumps, drop-offs, sand, rocks, gullies, logs, and inclines.

D.6.3 - Procedure

After a safety check, vehicles are positioned at the start line of the course. The track worker will check that the driver is ready to begin. Once the driver is ready, the track worker will signal the driver to proceed down the course. After completing the run on the course, the vehicle will be directed to the course exit.

Each vehicle may make two (2) attempts at the course.

D.6.4 - Signals and Signage

See D.9.9 - Signals and Signage.

D.6.5 - Penalties

The organizer may select a maximum of two (2) penalty types imposed for different violations to account for differences in the length or design of specific event courses. Penalties are times added to the total time a vehicle took to complete the course for a given run. The organizer will announce penalties on their event website or at a mandatory team meeting.

Example Penalties:

Pylon or Obstacle Moved – 2 seconds

Missed Gate – 10 seconds

D.6.6 - Scoring

The maximum number of available points for the maneuverability event is 70 points.

Scoring will be based on the better of the two attempts. Only vehicles that complete the maneuverability course within a time not exceeding 2.5 times that of the fastest vehicle will receive a score. If a vehicle is on the course for a time that exceeds 2.5 times the fastest time recorded to that point, then the attempt may be declared over and the vehicle may be removed from the course and scored as “Excess Time.”

Maneuverability scoring is based on the vehicle’s time to complete the course. Penalties are added to the vehicle’s time for a given run.

The following equation will be used for the maneuverability score (S_{ma}):

$$S_{ma} = 70 \times \frac{t_{max} - t_{run}}{t_{max} - t_{min}}$$

Where:

t_{min} is the lowest (fastest) time by any vehicle

t_{run} is the time recorded for a vehicle’s run to be scored.

t_{max} is the minimum of the following:

- The longest (slowest) time by any vehicle, or
- 2.5 times t_{min}

Article 7 - Specialty Events

Specialty events are designed to test the vehicle under unique off-road conditions that might be unique or specific to a particular Baja SAE® competition site.

Examples of specialty events are: Rock Crawl, Mud Bog, and Suspension.

The dynamic events at competitions differ. Teams should check the websites of the specific competitions they are planning to enter and consider any unique requirements that might affect the design and fabrication of their vehicle.

D.7.1 - Objective

Specialty events may require the vehicle to complete a course in a minimum time or proceed a maximum distance. The objective of specialty events is at the discretion of the organizer.

D.7.2 - Course

The course of specialty events is at the discretion of the organizer.

D.7.3 - Procedure

After a safety check, vehicles are positioned at the start line of the course. The track worker will check that the driver is ready to begin. Once the driver is ready, the track worker will signal the driver to proceed down the course. After completing the run on the course, the vehicle will be directed to the course exit.

Each vehicle may make two (2) attempts at the course.

D.7.4 - Penalties

Penalties for specialty events are at the discretion of the organizer.

D.7.5 - Signals and Signage

See D.9.9 - Signals and Signage.

D.7.6 - Scoring

The scoring system and penalties employed by the organizer must adhere to one of the options defined for either (a) the Maneuverability event, or (b) the Traction event. The maximum number of available points for the specialty event is 70 points.

Article 8 - Endurance

D.8.1 - Objective

The endurance event assesses each vehicle's ability to operate continuously and at speed over rough terrain with obstacles in potentially adverse weather conditions (rain, snow, etc.). The endurance event may be run for time or for distance. The default is four (4) hours and the vehicle with the most laps (orbits) around the course is declared the winner.

D.8.2 - Course

The endurance course is a closed loop measuring approximately 0.8 km (0.5 mi.) to 3.2 km (2 mi.). The endurance course will feature different surfaces (e.g. dirt, grass, sand, mud, gravel, stone, and asphalt). The endurance course will feature various obstacles and terrain to test the vehicle's durability, traction, and speed.

D.8.3 - Procedure

D.8.3.1 - Pre-Gridding

Teams will pre-grid before the endurance event and be placed into starting position based on each team's performance in a previous dynamic event, or set of dynamic events, to be determined by the organizer. Pre-gridding will close at a pre-determined time by SAE and the organizer. Teams late to pre-grid will be gathered in the fuel area and released to the track after the race has started.

D.8.3.2 - Compliance Check

During pre-gridding, or after pre-gridding closes, vehicle engines will be started and the NTI will perform a compliance check. During compliance check and gridding, the driver and vehicle may only have one team member accompany them. The compliance check includes, but is not limited to inspection of the following:

- Helmet Certification
- Helmet Fitment and Securement

- Safety Harness
- Driver Equipment
- Driver Wrist Band
- Fire Extinguisher
- Engine Kill Switches
- Brake System

Unprepared drivers or out-of-compliance vehicles deemed unsafe or not ready to drive will be ordered out of the gridding line by NTI and sent to the paddocks to make corrections. Vehicles not ready to drive must check in at the fuel area to be admitted to the track.

D.8.3.3 - Gridding

Once the compliance check is complete, vehicles begin to form the grid and approach the start line as marshaled by track workers or NTI.

D.8.3.4 - Starting

The endurance event may be started by a standing staggered start, rolling start, or holeshot. A standing staggered start is used to release cars in groups of two with a delay in between groups. A rolling start allows a run-in distance to the start line. The rolling start may be performed on the course. A holeshot is a start where all vehicles are lined up equidistant to the first course feature and started all at once. The start type will be determined by SAE and the organizer.

All vehicles will be considered to have begun the race simultaneously at the time when the starter releases the first vehicle onto the course regardless of their actual position in the grid.

D.8.3.5 - Running

Endurance will be run as either:

- A single four (4) hour race
- A predetermined and published distance
- Elimination heats followed by a final in which the total time of one elimination heat plus the final is 4 hours. The organizer (with approval from SAE International) will announce the structure of the event prior to the start.

Vehicles will safely navigate the course and accrue laps (orbits) to be counted and scored.

D.8.3.6 - Driver Change

Vehicle drivers may be changed at any time. Driver changes occur in the Fueling Area.

SAE reserves the right to require at least one driver change during the endurance event.

D.8.3.7 - Refueling

D.8.3.7.1 - Location

The Fueling Zone (FZ) consists of the Fueling Area (FA), Fuel Quarantine Area (FQ), Crew Area (CA) and Harness Check Area (HC).

Only three (3) people from any given team, including drivers, are allowed within the Fueling Zone (FZ) at any one time.

Active refueling occurs in the FA. All stored fuel not in use is located in the FQ. Vehicles and drivers will proceed to the HC before returning to the track.

D.8.3.7.2 - Procedure

Vehicles requiring fuel will exit the track at the designated location and proceed at walking-speed to the fueling area.

Before refueling, the vehicle must be stopped, the engine shut off, and the driver **completely out of the vehicle**. The driver may not be tethered in any way, by harness, communications equipment, or clothing.

Before refueling, a team's pit crew member must have a fire extinguisher ready and pointed at the fuel transfer point on the vehicle. The exiting driver is the only team member permitted to remove the fuel tank cap.

A team refueling their vehicle before the driver is clear of the vehicle or who fail to have a fire extinguisher present and pointed at the fuel transfer point will be penalized.

The fueling area is to be clear of anyone not immediately servicing a car.

A fire extinguisher must be present and pointed at ANY transfer of fuel, including re-filling a smaller container from a larger one when a vehicle is not present.

D.8.3.7.3 - Fuel Containers

Vehicles must be refueled using a fuel container no larger than 5.7 L (1.5 gal.) in volume.

D.8.3.7.4 - Fuel Storage

Each team shall have no more than two (2) approved fuel containers in the Fueling Area (FA). Any additional fuel containers, full or empty, shall be placed in the Fuel Quarantine area (FQ) for the duration of the endurance event. All fuel must be in the Fueling Zone (FZ) by the time endurance pre-gridding closes and safety checks begin. Any team found with fuel in the paddocks during the endurance event or found removing fuel from the Fueling Zone (FZ) without an escort from a NTI or designated official prior to the end of the endurance event will be assessed a penalty.

If a team wishes to remove their fuel from the Fueling Zone and leave the event site prior to the end of the endurance event, they must remove their "Passed Tech" sticker and provide it to a National Technical Inspector in exchange for their fuel.

D.8.3.7.5 - Repairs in Fueling Area

No work requiring a tool may be performed in the Fueling Area. Teams are allowed to make adjustments that do not require any tools. Examples include driver harness, seat position, spring-damper pre load, etc.

Teams may only have approved fuel containers (see B.6.8 - Fuel Containers), fire extinguishers, and funnels, if required, in the Fueling Area. Tools of any kind, backpacks, wagons, extra driver equipment, and coolers are specifically prohibited. Extra driver equipment may be brought to the Fueling Area for use but extra driver equipment may not be stored in the Fueling Area.

D.8.3.8 - Service

D.8.3.8.1 - Remote Pit

SAE and the organizer may elect to create a remote pit for minor repairs and adjustments.

D.8.3.8.2 - Paddocks

Teams whose vehicle requires service and repairs may exit the track at the designated location and proceed at walking speed to their paddock. No repairs are permitted on the course at any time.

D.8.3.9 - Recovery

Vehicles disabled on the endurance course may be recovered by track workers, or by a designated recovery crew. Track workers will attempt to assist disabled vehicles. It is the driver's responsibility to assist and cooperate with the course marshals in removing the vehicle. Drivers may not exit the vehicle to start the engine. Drivers must be seated and secured in the vehicle before track workers will attempt to restart the engine.

If track workers are unable to assist a disabled vehicle, a recovery crew will transport the disabled vehicle to the paddocks. Drivers being towed to the paddock are required to remain seated and secured in their vehicle with all safety equipment on.

Recovery crews are dispatched and operate on a "first come, first serve" basis. No priority will be given to any team over another.

D.8.3.10 - Finish

The Endurance event is finished when the lead car crosses the finish line after the time limit or distance has been reached. Vehicles remaining on the track will be allowed to finish their lap. Vehicles in the fuel zone will not be allowed back on the track after this time.

As vehicles cross the finish line, track workers will direct vehicles to the paddocks or the impound area (if required). All post-event traffic shall be at walking-speed.

D.8.3.11 - Impound

SAE reserves the right to impound and inspect any vehicle during or after the endurance event. NTI will direct and instruct teams in impound how to proceed.

Teams may be required to surrender their engine per D.9.8 - Surrender of Engine.

D.8.4 - Penalties

NTI are the only personnel permitted to call and assess penalties during the endurance event. NTI are distributed throughout the endurance course during the event. Penalties during the endurance race will be signaled from and vehicles ordered off the track from the black flag area. NTI may stop any vehicle, at any time, if they believe it no longer complies with the requirements and restrictions of the rules. All timed penalties are enforced from when the vehicle is in the black flag area, i.e. the time spent being towed back to the pits, does not count towards the penalty.

D.8.4.1 - Driver Equipment

Any driver that is not using all of the approved and required drivers' equipment will be flagged.

D.8.4.2 - Mechanical Faults

All cars must remain in the as-approved condition in order to compete; any condition that is deemed to not meet this requirement will be flagged to make necessary repairs or adjustments. If a vehicle is stopped by officials for a mechanical fault, the fault must be corrected before it may reenter the event.

D.8.4.3 - Vehicle Assists

Certain areas of the endurance course have been identified as difficult obstacles. If a vehicle is assisted two times on the same obstacle, the vehicle will be black flagged and the driver warned that one more assist will result in removal of the vehicle for the remainder of the event.

D.8.4.4 - Roll Over

If a vehicle rolls over (end over end, or over on its side) anywhere on the track two times (in any location, regardless of driver), the vehicle will be black flagged and the driver warned that one more roll over will result in removal of the vehicle for the remainder of the event. Roll overs will be judged at the discretion of NTI. Any vehicle that rolls over must be inspected by NTI before returning to the track.

D.8.4.5 - Endurance Penalty Table

Penalty Type	Infraction	1 st Offense	2 nd Offense	3 rd Offense
Fuel	Possession of fuel or fuel is removed from the fuel area after endurance gridding	10 minutes	20 minutes	DQ
Fuel	Unchecked fuel removed from fuel area during endurance	10 minutes	20 minutes	DQ
Fuel	Fueling on the track	DQ	-	-
Fuel	Use of tools on the car in the fuel area	Warning	10 minutes	DQ
Fuel	More than 3 people in the fuel area	Warning	10 minutes	DQ
Fuel	Fueling with the driver in the car	30 minutes	DQ	
Fuel	Fire extinguisher not ready during fueling	10 minutes	20 minutes	DQ
Fuel	Run out of fuel on the track	5 minutes	5 minutes	5 minutes
Driving	Vehicle Roll Over	-	Warning	DQ
Driving	Passing during a yellow flag	Warning	Discretionary	Discretionary
Driving	Failure to stop for black flag when signaled	10 minutes	Discretionary	Discretionary
Driving	Leaving the course and advancing	5 minutes	Discretionary	Discretionary
Driving	Aggressive driving	10 minutes	DQ	-
Driving	Speeding in the pit or paddocks	5 minutes	20 minutes	DQ

Figure D-2: Endurance Event, Table of Penalties

D.8.5 - Signals and Signage

See D.9.9 - Signals and Signage

D.8.6 - Scoring

D.8.6.1 - Points

The maximum possible points for endurance are 400 points.

D.8.6.2 - Determination of Winner

- a. The team that completes the distance of the competition first or the greatest number of scored laps in the time set for the competition will be declared the winner.
- b. In competitions of a given distance, the checkered flag will be given first to the leading car, then to the other finishers as they cross the finish line.
- c. In competitions of a timed length, the checkered flag will be given first to the leading car as it crosses the finish line at or after the expiration of the specified duration, then to the other finishers in the order they cross the finish line.
- d. If the leading car is not running at the expiration of the time limit, the checkered flag will be given to the next highest running car in the same manner.

D.8.6.3 - Scored Laps

Scored laps are the number of full laps actually completed during the endurance event. Only full laps count, partial laps do not count for score. A vehicle must cross the timing line under its own power for a lap to be counted.

D.8.6.4 - Finish Order

Finish order is the sequence in which vehicles cross the finish line after the lap scoring period has ended. Finish order determines the ranking of teams completing the same number of laps. For example, if the top four teams finish with the same number of laps, then they will be ranked 1st to 4th based on their finish order.

D.8.6.5 - Bonus Points

Bonus points are additional points awarded to the first ten (10) vehicles on the leading (winning) lap, as separated by finish order as required, in part to differentiate teams finishing with the same number of scored laps. Up to 10 bonus points will be awarded in the inverse order of finish. Thus, the first vehicle to cross the finish line in the highest lap group will receive bonus points equal to the number of cars on the lead lap (max of 10); the second vehicle will receive one less bonus point etc. Example:

Position	Lap	Bonus Points
1	48	4
2	48	3
3	48	2
4	48	1
5	47	0

Figure D-3: Endurance Event, Table of Bonus Points

D.8.6.6 - Score

Endurance scoring is based on number of laps the vehicle completes in the allowed time:

$$S_{en} = \left(400 \times \frac{l_{team} - l_{min}}{l_{max} - l_{min}} \right) + P_{bonus}$$

Where:

L_{max} is the maximum number of laps completed by any vehicle.

L_{team} is the number of laps completed by the vehicle to be scored.

L_{min} is the minimum number of laps completed by any vehicle.

P_{bonus} is the number of bonus points awarded to a qualifying vehicle.

D.8.6.7 - Heat Plus Final Scoring

When endurance is run as heats plus a final, the points for the event will be distributed between the heats and the final in proportion to the time/distance of each stage.

Thus, if endurance is run as one (1) hour eliminations plus a three (3) hour final, the four hundred (400) total points will be allocated as one hundred (100) points to each elimination heat plus three hundred (300) points to the final.

Article 9 - General Event Procedures and Regulations

D.9.1 - Safety

D.9.1.1 - Safety Vision

Safety is the primary consideration in the design of Baja SAE® vehicles and the conduct of the competitions. No event or competition is so important that teams and organizers cannot take the time to work safely. All participants will strive to create a safe competition where all participants return home in the same condition in which they arrived.

D.9.1.2 - First Aid / CPR / AED

While medical services are always on-site at Baja SAE® events, teams are encouraged to be familiar with or trained in first aid, CPR, and the use of AED machines.

D.9.1.3 - Approaching Others

All participants are empowered to directly and respectfully approach others if they see a hazardous or unsafe condition and notify the person in danger. Persons approached regarding a safety concern are obligated to respectfully acknowledge the situation and are encouraged to thank those who approached them for their concern.

D.9.1.4 - Responsibility

At all performance events, it is the responsibility of the team to ensure both the vehicle and driver meet and follow all the requirements and restrictions of the rules.

D.9.1.5 - Personal Protective Equipment

Teams are required to furnish and use their own PPE, appropriate for the task being performed. This includes, but is not limited to:

- Safety Glasses
- Gloves
- Closed Toe Shoes
- Arc Flash Protection
- Hearing Protection

D.9.1.6 - Key Hazards

All participants are encouraged to pay careful attention to the following situations:

D.9.1.6.1 - Ascending and Descending

Maintain 3-point contact when ascending and descending stairs, ladders, steps, or tailgates. Watch for obstructions at the beginning and end of travel.

D.9.1.6.2 - Pinch Points

Stay clear of pinch points from rotating machinery, doors, and other equipment.

D.9.1.6.3 - Hazardous Release of Energy

Stay clear of sparks, chips, swarf, or other high-energy material. Check circuits for live wires before working on them. Depressurize high pressure air, oil, or water systems before working on them. Take care when working around presses, rams, or other hydraulic equipment. Use care when jacking or lifting vehicles or other objects.

D.9.1.6.4 - Vehicle Operations

Do not drive when distracted. Utilize a spotter when backing a vehicle, especially with a trailer.

D.9.1.6.5 - Walking / Path of Travel

Take care to keep all walking paths clear of slip, trip, and fall hazards.

D.9.2 - Rules of Conduct

D.9.2.1 - Sportsmanlike Conduct

All Baja SAE® participants can be proud of the excellent sportsmanship and cooperation among teams that are two of the hallmarks of the series. Good conduct and compliance with the rules and the official instructions are expectations and requirements for every team member.

Unsportsmanlike conduct can include arguments with officials, disobedience of official instructions and the use of abusive or threatening language to any official or other participant. Depending on the seriousness of the infraction the penalty for such actions can range from a deduction of up to fifty percent (50%) of the team's points to expulsion of the entire team. Penalties of this type will only be imposed after a complete review of the incident by the organizer and SAE International staff.

D.9.2.1.1 - Prohibited Material

Alcoholic beverages, marijuana, firearms, weapons of any type, and illegal materials are prohibited at Baja SAE® sites during the competition. The penalty for violation of this rule is the immediate expulsion

of the entire team, not just the individual(s) involved. This rule applies to team members, advisors and any individuals working with the team on-site.

D.9.2.1.2 - Tobacco Products and Electronic Cigarettes

The use of all tobacco and marijuana products or using e-cigarettes on-site is prohibited.

D.9.2.1.3 - Footwear

All individuals on-site shall wear durable and sturdy footwear. Open-toed shoes are explicitly prohibited.

D.9.2.1.4 - Parties

Disruptive parties either on or off-site must be prevented by the faculty advisor or team captain.

D.9.2.1.5 - Housekeeping

Clean-up of trash and debris is the responsibility of the teams. Please make an effort to keep the paddock area clean and uncluttered. At the close of the day, each team must clean their work area.

D.9.2.1.6 - Site Condition

Please help the organizers keep the site clean. The sites used for Baja SAE® are generally private property and should be treated as such. Competitors are reminded that they are guests. All trash should be placed in the receptacles provided. Glass is not allowed on the grounds. Failure to clean the premises will result in an unsportsmanlike conduct penalty. Competitors are encouraged to clean their areas after meals.

D.9.2.1.7 - Personal Transportation

The use of motorcycles, quads, bicycles, scooters, skateboards, rollerblades or similar person-carrying or motor driven devices by team members and spectators in any part of the competition area, including the paddocks is prohibited.

D.9.2.2 - Spectator Rules

D.9.2.2.1 - General

The organizers typically do not have a direct line of communication with spectators other than on-the-spot at the competition; thus, the competitors, faculty and volunteers are expected to help inform the spectators of the safety rules and help restrict spectators to the spectator areas.

D.9.2.2.2 - Alcoholic Beverages

Spectators may not drink or possess alcoholic beverages at any competition location.

D.9.2.2.3 - Access Restriction

Spectators must keep-back a specified distance from the event areas as decided by SAE International and the organizers and from any area where vehicles are operating under power. Motor vehicle competitions are potentially dangerous and safety rules will be strictly enforced.

D.9.2.2.4 - Children

A competition site is not a safe place for children and unsupervised young people. Spectators who fail to strictly control their children will be asked to leave the site.

D.9.2.2.5 - Expulsion

The course officials and organizers have the absolute right to restrict spectator access to any parts of the site and to eject anyone who violates safety rules or ignores the instructions of officials.

D.9.2.2.6 - Unsafe Conduct

All participants are required to exercise safe practices and avoid unsafe activities at all times during the competition. The event organizer and SAE have the discretionary authority to impose a just penalty for any conduct deemed unsafe. All team members will be held to this rule.

D.9.3 - Paddock Rules

D.9.3.1 - Refueling

Before refueling, the vehicle must be stopped, the engine shut off, and the driver completely out of the vehicle. The driver may not be tethered in any way, by harness, communications equipment, or clothing.

Before refueling, a team's pit crew member must have a fire extinguisher ready and pointed at the fuel transfer point on the vehicle. The exiting driver is the only team member permitted to remove the fuel tank cap.

A team refueling their vehicle before the driver is clear of the vehicle or who fail to have a fire extinguisher present and pointed at the fuel transfer point will be penalized. For infractions occurring prior to the endurance race, the penalty will be assessed during the endurance race.

D.9.3.2 - Speed Limit

When a vehicle is driven anywhere except within the practice area or on event courses it must move at walking speed with a team member walking along side at a normal pace. During the performance events when the excitement is high, it is particularly important that vehicles move at a walking pace in the paddocks. The walking speed rule will be strictly enforced and discretionary point penalties will be assessed for violations.

D.9.3.3 - Escort Required

When a vehicle is driven anywhere except within the practice area or on event courses, it must have a team member escort the vehicle. The escort shall walk with the vehicle on the right side (to stay close to the firewall kill switch) and shall remain in the view of the driver at all times. The escort should act as a spotter to the driver, paying special attention to the vehicle's blind spots and other vehicles.

Under no circumstances may anyone other than the driver, ride in or on a vehicle.

Escorts shall remain clear and not touch the vehicle when it is in motion and remain within line-of-sight to the driver.

D.9.3.4 - Team Work Area

The team's work area should be clearly defined and should be kept uncluttered at all times. When a team leaves their area, it must be left clean.

D.9.3.5 - Team Vehicles

Only the Baja SAE® vehicles themselves and the teams' support trucks and trailers are allowed in the paddocks.

D.9.3.6 - Access Restriction

The organizers may limit the paddocks to team members, faculty advisors and competition officials.

D.9.3.7 - Compressed Gases

Teams shall safely store compressed gas cylinders. Cylinders shall be upright and properly secured by chain or other method, capped when not in use, and stored such that cylinder temperature is below 52 deg. C (125 deg F).

D.9.3.8 - Driving Restrictions

D.9.3.8.1 - Off Site Operation

During the competition, Baja SAE® vehicles may only be driven between the paddocks and an event site, during official practice, or in the events themselves and only after the vehicle has passed technical inspection.

Driving off site is explicitly prohibited. Teams found to have driven their vehicle at an off-site location during the event may be expelled from the competition.

D.9.3.8.2 - Driver Equipment

Drivers not wearing the proper equipment will not be permitted to drive, and may have their competition driver's privileges revoked.

D.9.4 - Meetings

All team members identified as captains or drivers and all faculty advisors MUST attend all meetings as designated; Attendance at meetings is mandatory. Failure to attend meetings can result in disqualification of members or the entire team.

D.9.5 - Tie Breakers

D.9.5.1 - Non-Endurance Events

Ties for non-endurance dynamic events will be broken by comparing the score of the second best time or distance for the event in question. If the tie remains, the tie stands.

D.9.5.2 - Endurance Event

Ties in the endurance race will be judged by the endurance event judge and may remain a tie.

D.9.5.3 - Overall Event

Ties for the overall winner will be broken in the following order:

- 1) Endurance Score
- 2) Total Dynamic Events Score
- 3) Total Static Events Score

If a tie remains after the prescribed tie breakers, the tie stands for the overall winners.

D.9.6 - Pre Inspection Operation

Vehicles may not be started or driven prior to passing technical inspection, except as required as part of the inspection process itself.

D.9.7 - Inspection

Any vehicle may be impounded and inspected anytime during the competition. Any vehicle found to have: altered or substituted its parts or equipment since passing technical inspection or an engine in violation of the rules may receive a point deduction of 75 points each time it is found in violation.

D.9.8 - Surrender of Engine

The organizers and SAE International may, recall the engine from any vehicle in the competition in exchange for a new engine. Recalled engines will not be returned and will be inspected to confirm compliance with the rules.

D.9.9 - Signals and Signage

Baja SAE® competitions may use some or all of the signals and signage presented in this section.

D.9.9.1 - Green Flag

- a) When displayed at a starting line or when reentering the course: The event has started; enter the course under the direction of the starter.
- b) When running on the course: Course is clear, proceed.

Note: Green flags may also be represented by green lights at designated locations.

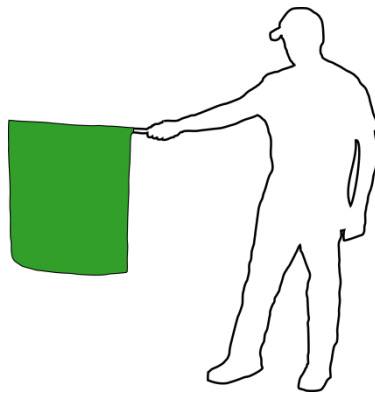

Figure D-4: Signals and Signage, Green Flag

D.9.9.2 - Yellow Flag

When displayed, there is a dangerous situation on the track beyond the flag station. Reduce speed and be prepared to take evasive action or stop on the track. Passing is not permitted, unless directed by the course workers.

Note: Yellow flags may also be represented by yellow lights at designated locations.

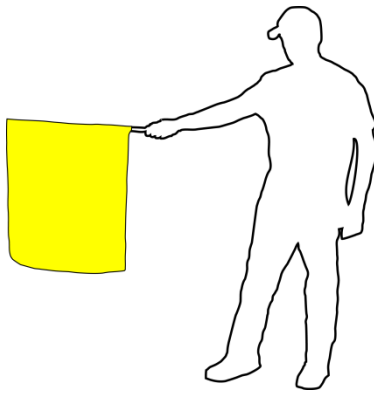

Figure D-5: Signals and Signage, Yellow Flag

D.9.9.3 - Red Flag

When displayed, there is a dangerous situation somewhere on the track requiring a full-course stop. Come to an immediate, safe, and controlled stop on the course. Passing is not permitted. Pull to the side of the track as much as possible to keep the course open. Follow course worker directions.

Note: Red flags may also be represented by red lights at designated locations.

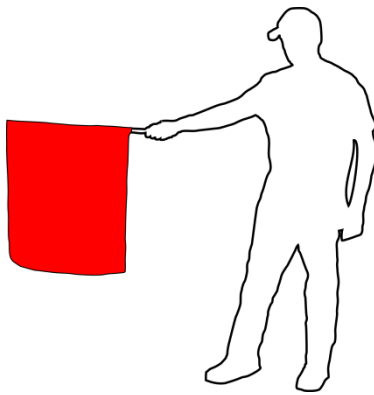

Figure D-6: Signals and Signage, Red Flag

D.9.9.4 - Black Flag (Displayed)

- a) Pull into the penalty box for a discussion with the NTI or other official concerning an incident. A penalty may be assessed for the incident.
- b) Pull into the penalty box for a mechanical inspection of the car; a dangerous condition has been observed on the vehicle.

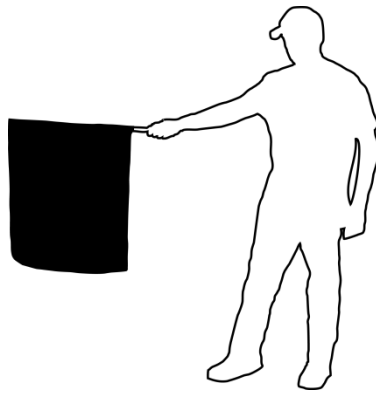

Figure D-7: Signals and Signage, Black Flag

D.9.9.5 - Black Flag (Furled and Pointed)

Warning, the officials are watching this vehicle's driving – obey the event rules.

D.9.9.6 - Checkered Flag

The event has been completed. Exit the course as directed by event officials.

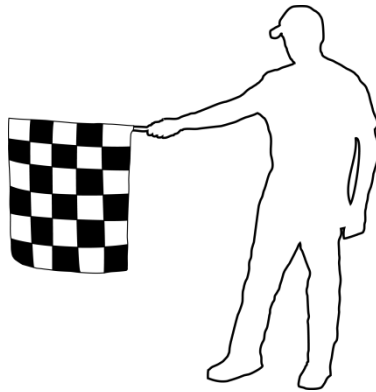

Figure D-8: Signals and Signage, Checkered Flag

D.9.9.7 - Directional Arrow

Orange triangle with a 1.5:1 height to base ratio, with or without forked base. White or black trim is optional. The minimum base width is 6 inches.

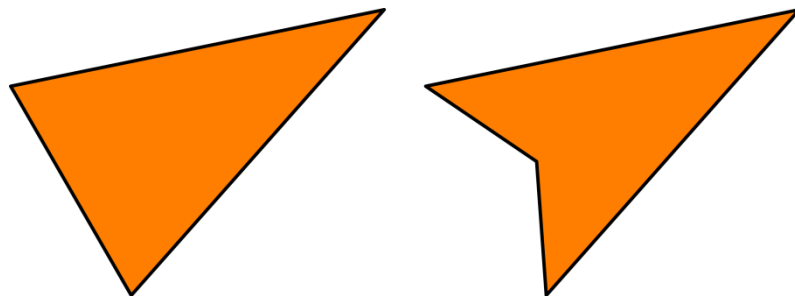

Figure D-9: Signals and Signage, Directional Arrow

D.9.9.8 - Control Zone Boundary

This sign denotes the beginning of the control zone around an event. Beyond this sign, the vehicle and driver must be ready to run the event. The driver must have all required equipment on and the vehicle

may not have any adjustments made. Beyond this sign, one team member is allowed to accompany the vehicle. Teams entering the control zone not ready to run or with more than one attendant may be sent to the back of the line.



Figure D-10: Signals and Signage, Control Zone Boundary

D.9.9.9 - Time Control Marshal

This sign denotes the location of the time control marshal. The time control marshal will position your vehicle to start the event. At this location NTI may do a final compliance check on your vehicle.

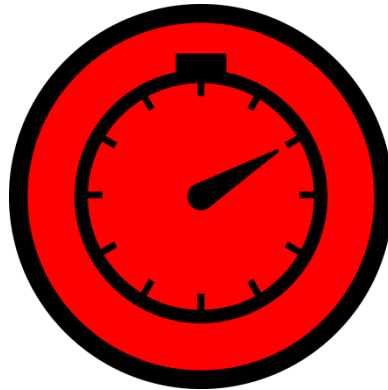

Figure D-11: Signals and Signage, Time Control Marshal

D.9.9.10 - Start Line

This sign denotes the location of the event starting line. At this location the driver will be given the signal from the start marshal to begin the run.

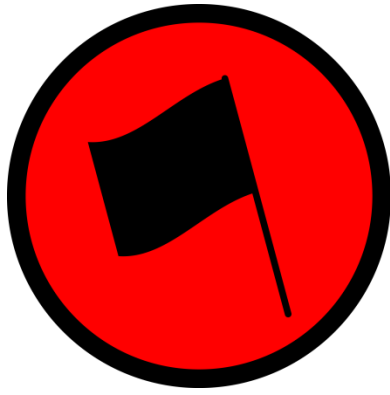

Figure D-12: Signals and Signage, Start Line

D.9.9.11 - Finish Line

This sign denotes the end of the run, where a time or distance will be taken. Proceed through the finish line to record your score.

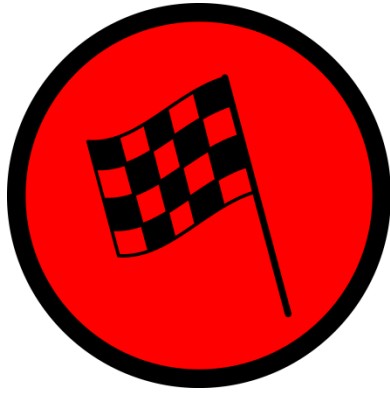

Figure D-13: Signals and Signage, Finish Line

D.9.9.12 - Stop Line

All vehicles are required to stop at the stop line at the end of the run. At this location, proceed only upon the instruction of the Finish Marshal.



Figure D-14: Signals and Signage, Stop Sign

D.9.9.13 - End Control Zone

This sign denotes the end of the control zone boundary.

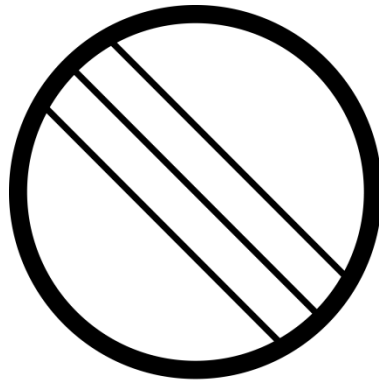

Figure D-15: Signals and Signage, End Control Zone

D.9.9.14 - Begin Fuel Zone

This sign indicates the beginning of the fuel zone where fueling is permitted.



Figure D-16: Signals and Signage, Begin Fuel Zone

D.9.9.15 - End Fuel Zone

This sign denotes the end of the fuel zone. Beyond this sign fueling is not permitted unless approved by the Fuel Zone Official.



Figure D-17: Signals and Signage, End Fuel Zone

D.9.9.16 - Begin Service

This sign denotes the beginning of the service area (paddocks and/or hot pit). Beyond this sign, vehicle adjustments, service, and/or maintenance are permitted.



Figure D-18: Signals and Signage, Begin Service Area

D.9.9.17 - End Service

This sign denotes the end of the service area (paddocks and/or hot pit). Beyond this sign, vehicle adjustments, service, and/or maintenance are not permitted.



Figure D-19: Signals and Signage, End Service Area

Part E : Appendices

Article 1 - List of Abbreviations

AED, 97
ALC, 25, 28, 29, 60
AN/MS, 72
ATA, 12
BLC, 25, 29, 60
CDS, 9, 15, 17
CLC, 25, 31
CPR, 97
CVT, 64
DLC, 25, 28, 35
DQ, 88, 94, 95
FA, 92, 93
FAB, 26, 28, 37, 38
FBM, 25, 37
FLC, 25, 28, 34
FQ, 92, 93
FZ, 92, 93
IMechE, 12
LDB, 26, 29, 30
LED, 69
AED – Automatic External Defibrillator
AN/MS – Army/Navy Military Standard
CDS – Collegiate Design Series
CPR – Cardio Pulmonary Resuscitation
CV – Constant Velocity
CVT – Continuously Variable Transmission
DF – Design Finals
DQ - Disqualified
FA – Fuel Area
FEA – Finite Element Analysis
FQ – Fuel Quarantine
FZ – Fuel Zone
ID – Inside Diameter

LFS, 25, 34, 37, 51, 61, 70
MB, 42, 81
NTI, 10, 11, 47, 51, 59, 60, 72, 80, 91, 92, 93, 94,
101, 102
OEM, 67, 69
PDF, 42, 81
RF, 70, 75
RHO, 25, 31, 33, 37, 41
RLC, 26
RPM, 22, 79
RRH, 25, 29, 30, 33, 34, 35, 37, 38, 41, 45, 46, 51,
59, 60, 62, 68, 69, 75
SAE, 1, 8, 9, 10, 11, 12, 13, 14, 15, 16, 17, 18, 19,
21, 41, 43, 51, 53, 56, 69, 71, 73, 76, 79, 81, 82,
87, 90, 91, 92, 93, 94, 96, 97, 98, 99, 100
SFI, 43, 44, 49, 52, 53
SIM, 25, 26, 35, 37, 61, 63, 70, 75, 76
USM, 26, 36, 51
VDI, 12
IMechE – Institution of Mechanical Engineers
LED – Light Emitting Diode
MB - Megabyte
NTI – National Technical Inspectors
OEM – Original Equipment Manufacturer
PDF – Portable Document Format by Adobe
RF – Radio Frequency
RPM – Revolutions per minute
SAE – Society of Automotive Engineers
SFI – SEMA Foundation Inc.
VDI – Association of German Engineers
XLS – Excel Spreadsheet by Microsoft

